



## **Virdis Energy**

Rendamax R3456 EVO Floor Standing  
Condensing Boiler

Brochure





# R3456 EVO — Class-Leading Outputs with Extremely Low Emissions

## Outstanding design

The R3456 EVO offers unrivalled power and performance, delivering outputs up to 2 MW, thanks to a one-of-a-kind boiler design.

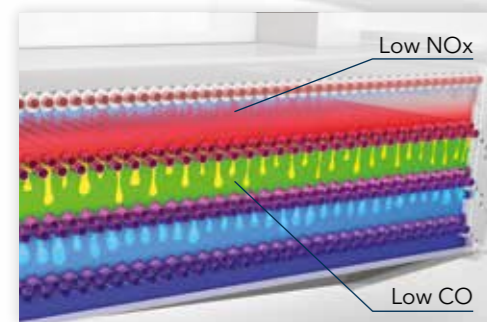

## Extremely low emissions

By combining a unique heat exchanger geometry and a water-cooled cold flame burner, the R3456 EVO offers class-leading performance for low NOx and CO.



## Modular construction

Rendamax's renowned modular design construction allows the R3456 EVO to be disassembled into components parts - providing flexibility when siting the boilers in a commercial property.



## Comprehensive control features

Designed for simple system integration, the R3456 EVO can operate alongside multiple energy sources, while a master-slave cascade function makes commissioning easy.



## BMS connections

The R3456 EVO is compatible with common building managements system protocols, utilising the Commercial Gateway for a hassle-free connection.



## Easy transportation and installation

Integral cargo wheels allow all models to be easily manoeuvred on site.

## Designed for complex systems

The latest commercial heating systems often include multiple heat sources, such as solar, heat pumps and CHP units. As a result, they are becoming more complex and heavily reliant on efficient heat distribution throughout the building.

These demands require accurate hydraulic balancing, which is best achieved using a low loss header or buffer. However, these systems also demand a degree of flexibility and reaction time from integrated heat sources.

Rendamax designs its boilers to meet all of these needs by utilising:

## Low water content technology

R3456 EVO boilers are fast, furious and respond rapidly - even in complex installations when combined with other heat sources.

## Example comparison:

- The heat up time for a high water content boiler from cold condition to standby temperature is 280 seconds.
- A comparable R3456 EVO boiler needs just 30 seconds.

## Compact dimensions and low operating weight

A small footprint and a lightweight construction ensure compatibility with a wide range of applications.

## Rooftop installations/rooftop plant room

By utilising low water content technology, multiple boilers can be situated on rooftops, without any concern over reinforcing the floor - while also delivering superb response times and reduced running costs.



# R3456 EVO — Performance for all Projects

## The complete range

The R3456 EVO range comprises four models that all offer powerful performance, topped by an industry first 2 MW version.

R3400 EVO	R3500 EVO	R3600 EVO	R3610 EVO (2 MW)
<p><b>Low condensing:</b></p> <ul style="list-style-type: none"> <li>• 650 - 1.900 kW</li> <li>• 10 models</li> <li>• 103,9 % efficiency</li> <li>• NOx (EN 15502)= 23 mg/kWh</li> </ul> <p><b>Applications:</b></p> <ul style="list-style-type: none"> <li>• High power/temperature</li> <li>• Cost driven</li> </ul> <p><b>3 sections:</b></p> <ul style="list-style-type: none"> <li>• 1 burner</li> <li>• 2 HEX-sections</li> </ul> 	<p><b>Medium condensing:</b></p> <ul style="list-style-type: none"> <li>• 650 - 1.600 kW</li> <li>• 9 models</li> <li>• 104,1 % efficiency</li> <li>• NOx (EN 15502)= 22 mg/kWh</li> </ul> <p><b>Applications:</b></p> <ul style="list-style-type: none"> <li>• Medium efficiency</li> <li>• Reduced energy consumption</li> </ul> <p><b>3 sections:</b></p> <ul style="list-style-type: none"> <li>• 1 burner</li> <li>• 2 HEX-sections</li> </ul> 	<p><b>High condensing:</b></p> <ul style="list-style-type: none"> <li>• 700 - 1.700 kW</li> <li>• 9 models</li> <li>• 109,7 % efficiency</li> <li>• NOx (EN 15502)= 22 mg/kWh</li> </ul> <p><b>Applications:</b></p> <ul style="list-style-type: none"> <li>• High power/high efficiency</li> <li>• Low energy consumption</li> </ul> <p><b>4 sections:</b></p> <ul style="list-style-type: none"> <li>• 1 burner</li> <li>• 3 HEX-sections</li> </ul> 	<p><b>High condensing:</b></p> <ul style="list-style-type: none"> <li>• 2.000 kW</li> <li>• 1 model</li> <li>• 109,7 % efficiency</li> <li>• NOx (EN 15502)= 23 mg/kWh</li> </ul> <p><b>Applications:</b></p> <ul style="list-style-type: none"> <li>• High power/high efficiency</li> <li>• Low energy consumption</li> </ul> <p><b>5 sections:</b></p> <ul style="list-style-type: none"> <li>• 1 burner</li> <li>• 4 HEX-sections</li> </ul> 
<p>Achieves <b>MAXIMUM BREEAM CREDITS 2</b></p>	<p>Achieves <b>MAXIMUM BREEAM CREDITS 2</b></p>	<p>Achieves <b>MAXIMUM BREEAM CREDITS 2</b></p>	<p>Achieves <b>MAXIMUM BREEAM CREDITS 2</b></p>

An industry **FIRST**

# Technical Data R3400 EVO

R3400 EVO		R3401 EVO	R3402 EVO	R3403 EVO	R3404 EVO	R3405 EVO	R3406 EVO	R3407 EVO	R3408 EVO	R3409 EVO	R3410 EVO
Nominal heat output at 80/60°C	kW	650	726	849	961	1073	1184	1296	1481	1666	1851
Minimum heat output at 80/60°C	kW	164	183	213	242	270	298	326	373	419	466
Nominal heat output at 50/30°C	kW	650	726	849	961	1074	1185	1297	1482	1667	1853
Minimum heat output at 50/30°C	kW	181	201	235	267	298	328	359	410	462	513
Nominal heat input Hi full load	kW	702	784	917	1038	1159	1279	1400	1600	1800	2000
Minimum heat input Hi min, load	kW	176	196	229	260	290	320	350	400	450	500
Efficiency at 80/60°C Hi full load	%	92,6	92,6	92,6	92,6	92,6	92,6	92,6	92,6	92,6	92,6
Efficiency at 50/30°C Hi min, load	%	102,6	102,6	102,6	102,6	102,6	102,6	102,6	102,6	102,6	102,6
Efficiency at 40/30°C Hi min, load	%	103,9	103,9	103,9	103,9	103,9	103,9	103,9	103,9	103,9	103,9
Annual efficiency (NNG 40/30°C)	%	103,3	103,3	103,3	103,3	103,3	103,3	103,3	103,3	103,3	103,3
NOx level (EN 15502)	mg/kWh	23	23	23	23	23	23	23	23	23	23
Flue gas temperature at 80/60°C full load	°C	182	182	182	182	182	182	182	182	182	182
Max, permissible flue resistance	Pa	150	150	150	150	150	150	150	150	150	150
Water pressure max,/min,	bar	8/1,5	8/1,5	8/1,5	8/1,5	8/1,5	8/1,5	8/1,5	8/1,5	8/1,5	8/1,5
Maximum temperature setpoint	°C	90	90	90	90	90	90	90	90	90	90
Water flow at ΔT=10K	m³/h	56,0	62,0	72,0	82,0	92,0	102,0	112,0	128,0	144,0	160,0
Hydraulic resistance at ΔT=10K	kPa	184	212	144	172	200	232	364	240	520	660
Water flow at ΔT=20K	m³/h	28,0	31,0	36,0	41,0	46,0	51,0	56,0	64,0	72,0	80,0
Hydraulic resistance at ΔT=20K	kPa	46	53	36	43	50	58	91	60	130	165
Electrical connection	V	400	400	400	400	400	400	400	400	400	400
Electrical power consumption boiler (excl, pump)	W	900	900	1270	1270	1270	1270	2330	2330	2770	2770
Noise level	dB(A)	72,7	72,7	72,7	72,7	72,7	72,7	72,7	72,7	72,7	72,7
Water content	l	50	53	70	75	80	85	97	109	116	123
Weight (empty)	kg	770	844	958	1084	1221	1369	1380	1740	1899	1991
<b>Dimensions</b>											
Water connections (W)	-	DN65 PN16	DN65 PN16	DN80 PN16	DN80 PN16	DN80 PN16	DN80 PN16	DN80 PN16	DN80 PN16	DN80 PN16	DN80 PN16
Gas connection (G)	-	R2"	R2"	R2"	R2"	DN65 PN16	DN65 PN16	DN65 PN16	DN65 PN16	DN80 PN16	DN80 PN16
Flue gas connection (C)	mm	300	350	350	400	400	400	450	450	500	500
Air intake connection (for room sealed use)	mm	250	355	355	355	355	355	450	450	450	450
Condensate connection	mm	40	40	40	40	40	40	40	40	40	40
Boiler length (incl, connections)	mm	2185	2185	2565	2565	2565	2565	2795	3310	3310	3310
Boiler length (excl, connections) (L1)	mm	1710	1710	2085	2085	2085	2015	2085	2600	2600	2600
Length water connections (Lw)	mm	475	475	480	480	480	480	480	480	480	480
Length chimney plate (L2)	mm	420	550	550	550	550	550	710	710	710	710
Width (B)	mm	1370	1370	1170	1170	1370	1370	1570	1370	1570	1570
Height (H)	mm	1555	1555	1555	1555	1555	1555	1555	1575	1575	1575

# Technical Data R3500 EVO

R3500 EVO		R3501 EVO	R3502 EVO	R3503 EVO	R3504 EVO	R3505 EVO	R3506 EVO	R3507 EVO	R3508 EVO	R3509 EVO
Nominal heat output at 80/60°C	kW	615	719	814	909	1003	1097	1255	1411	1568
Minimum heat output at 80/60°C	kW	175	204	231	258	285	311	356	400	445
Nominal heat output at 50/30°C	kW	620	725	821	917	1011	1106	1265	1422	1581
Minimum heat output at 50/30°C	kW	192	224	254	284	314	343	392	440	490
Nominal heat input Hi full load	kW	653	764	865	966	1066	1166	1333	1499	1666
Minimum heat input Hi min, load	kW	187	218	247	276	305	333	381	428	476
Efficiency at 80/60°C Hi full load	%	94,1	94,1	94,1	94,1	94,1	94,1	94,1	94,1	94,1
Efficiency at 50/30°C Hi min, load	%	102,9	102,9	102,9	102,9	102,9	102,9	102,9	102,9	102,9
Efficiency at 40/30°C Hi min, load	%	104,1	104,1	104,1	104,1	104,1	104,1	104,1	104,1	104,1
Annual efficiency (NNG 40/30°C)	%	103,7	103,7	103,7	103,7	103,7	103,7	103,7	103,7	103,7
NOx level (EN 15502)	mg/kWh	22	22	22	22	22	22	22	22	22
Flue gas temperature at 80/60°C full load	°C	153	153	153	153	153	153	153	153	153
Max, permissible flue resistance	Pa	150	150	150	150	150	150	150	150	150
Water pressure max./min,	bar	8/1,5	8/1,5	8/1,5	8/1,5	8/1,5	8/1,5	8/1,5	8/1,5	8/1,5
Maximum temperature setpoint	°C	90	90	90	90	90	90	90	90	90
Water flow at ΔT=10K	m³/h	52	62	70	78	86	94	108	122	134
Hydraulic resistance at ΔT=10K	kPa	148	100	120	140	160	240	288	372	456
Water flow at ΔT=20K	m³/h	26,0	31,0	35,0	39,0	43,0	47,0	54	61	67,0
Hydraulic resistance at ΔT=20K	kPa	37	25	30	35	40	60	72	93	114
Water flow at ΔT=30K	m³/h	17,3	20,7	23,3	26,0	28,7	31,3	36,0	40,7	44,7
Hydraulic resistance at ΔT=30K	kPa	16	11	13	16	18	27	32	41	51
Electrical connection	V	400	400	400	400	400	400	400	400	400
Electrical power consumption boiler (excl, pump)	W	900	900	1270	1270	1270	2330	2330	2770	2770
Noise level	dB(A)	68,7	68,7	68,7	68,7	68,7	68,7	68,7	68,7	68,7
Water content	l	53	70	75	80	85	97	109	116	123
Weight (empty)	kg	844	958	1084	1221	1369	1380	1740	1899	1991
<b>Dimensions</b>										
Water connections (W)	-	DN65 PN16	DN80 PN16	DN80 PN16	DN80 PN16	DN80 PN16	DN80 PN16	DN80 PN16	DN80 PN16	DN80 PN16
Gas connection (G)	-	R2"	R2"	R2"	DN65 PN16	DN65 PN16	DN65 PN16	DN65 PN16	DN80 PN16	DN80 PN16
Flue gas connection (C)	mm	350	350	400	400	400	450	450	500	500
Air intake connection (for room sealed use)	mm	355	355	355	355	355	450	450	450	450
Condensate connection	mm	40	40	40	40	40	40	40	40	40
Boiler length (incl, connections)	mm	2185	2565	2565	2565	2565	2795	3310	3310	3310
Boiler length (excl, connections) (L1)	mm	1710	2085	2085	2085	2085	2085	2600	2600	2600
Length water connections (Lw)	mm	475	480	480	480	480	480	480	480	480
Length chimney plate (L2)	mm	550	550	550	550	550	710	710	710	710
Width (B)	mm	1370	1170	1170	1370	1370	1570	1370	1570	1570
Height (H)	mm	1555	1555	1555	1555	1555	1555	1575	1575	1575

# Technical Data R3600 EVO

R3600 EVO		R3601 EVO	R3602 EVO	R3603 EVO	R3604 EVO	R3605 EVO	R3606 EVO	R3607 EVO	R3608 EVO	R3609 EVO	R3610 EVO
Nominal heat output at 80/60°C	kW	639	747	846	945	1043	1141	1304	1467	1630	1953
Minimum heat output at 80/60°C	kW	182	212	241	269	297	324	371	417	464	487
Nominal heat output at 50/30°C	kW	676	791	896	1001	1104	1208	1381	1553	1726	2069
Minimum heat output at 50/30°C	kW	202	236	267	298	330	360	412	463	515	541
Nominal heat input Hi full load	kW	653	764	865	966	1066	1166	1333	1499	1666	2000
Minimum heat input Hi min. load	kW	187	218	247	276	305	333	381	428	476	500
Efficiency at 80/60°C Hi full load	%	97,8	97,8	97,8	97,8	97,8	97,8	97,8	97,8	97,8	97,7
Efficiency at 50/30°C Hi min. load	%	108,2	108,2	108,2	108,2	108,2	108,2	108,2	108,2	108,2	108,2
Efficiency at 40/30°C Hi min. load	%	109,7	109,7	109,7	109,7	109,7	109,7	109,7	109,7	109,7	109,7
Annual efficiency (NNG 40/30°C)	%	109,1	109,1	109,1	109,1	109,1	109,1	109,1	109,1	109,1	109,1
NOx level (EN 15502)	mg/kWh	22	22	22	22	22	22	22	22	22	23
Flue gas temperature at 80/60°C full load	°C	69	69	69	69	69	69	69	69	69	73
Max. permissible flue resistance	Pa	150	150	150	150	150	150	150	150	150	150
Water pressure max./min.	bar	8/1,5	8/1,5	8/1,5	8/1,5	8/1,5	8/1,5	8/1,5	8/1,5	8/1,5	8/1,5
Maximum temperature setpoint	°C	90	90	90	90	90	90	90	90	90	90
Water flow at ΔT=10K	m³/h	54	64	72	82	90	98	112	126	140	168
Hydraulic resistance at ΔT=10K	kPa	296	160	180	268	312	328	384	544	648	864
Water flow at ΔT=20K	m³/h	27,0	32,0	36,0	41,0	45,0	49,0	56,0	63,0	70,0	84,0
Hydraulic resistance at ΔT=20K	kPa	74	40	45	67	78	82	96	136	162	216
Water flow at ΔT=30K	m³/h	18	21,3	24	27,3	30	32,7	37,3	42	46,7	56,0
Hydraulic resistance at ΔT=30K	kPa	33	18	20	30	35	37	43	60	72	96
Electrical connection	V	400	400	400	400	400	400	400	400	400	400
Electrical power consumption boiler (excl. pump)	W	900	900	1270	1270	1270	2330	2330	2770	2770	2770
Noise level	dB(A)	68,7	68,7	68,7	68,7	68,7	68,7	68,7	68,7	68,7	72,7
Water content	l	73	97	104	110	117	131	147	157	166	209
Weight (empty)	kg	1136	1328	1468	1634	1800	1900	2000	2100	2201	2500
<b>Dimensions</b>											
Water connections (W)	-	DN65 PN16	DN80 PN16	DN80 PN16	DN80 PN16	DN80 PN16	DN80 PN16	DN80 PN16	DN80 PN16	DN80 PN16	DN80 PN16
Gas connection (G)	-	R2"	R2"	R2"	DN65 PN16	DN65 PN16	DN65 PN16	DN65 PN16	DN80 PN16	DN80 PN16	DN80 PN16
Flue gas connection (C)	mm	300	350	350	400	400	450	450	500	500	500
Air intake connection (for room sealed use)	mm	250	355	355	355	355	450	450	450	450	450
Condensate connection	mm	40	40	40	40	40	40	40	40	40	40
Boiler length (incl. connections)	mm	2185	2565	2565	2565	2565	2795	3310	3310	3310	3310
Boiler length (excl. connections)(L1)	mm	1710	2085	2085	2085	2085	2085	2600	2600	2600	2600
Length water connections (Lw)	mm	475	480	480	480	480	480	480	480	480	480
Length chimney plate (L2)	mm	550	550	550	550	550	710	710	710	710	710
Width (B)	mm	1370	1170	1170	1370	1370	1570	1370	1570	1570	1570
Height (H)	mm	1555	1555	1555	1555	1555	1555	1575	1575	1575	1665



# Dimensions R3456 EVO

## Dimensions

- R3401-R3405 EVO
- R3501-R3506 EVO
- R3601-R3605 EVO

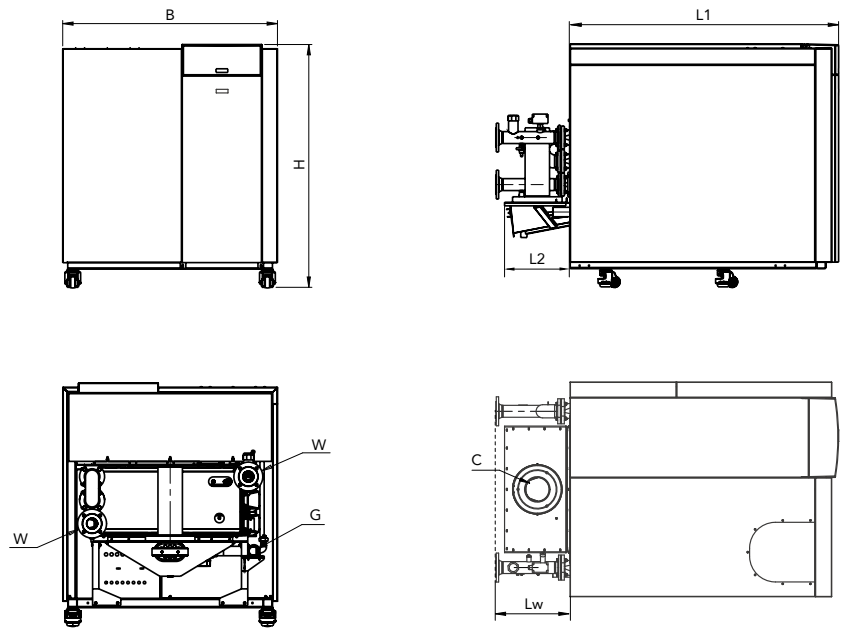

## Dimensions

- R3406-R3410 EVO
- R3507-R3509 EVO
- R3606-R3610 EVO

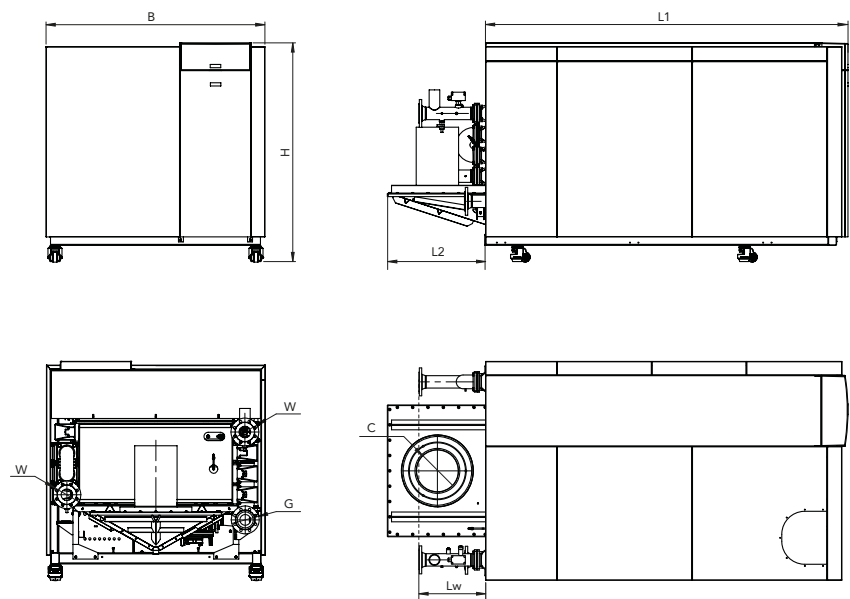

For detailed dimension indications please consult the R3456 EVO technical manual.



Phone: 0333 567 1121

Email: [hello@viridis.energy](mailto:hello@viridis.energy)

[www.viridis.energy](http://www.viridis.energy)

Viridis Energy, 201 High St, Henley-in-Arden B95 5BA