



Viridis Energy

Rendamax R0000 Wall Mounted
Condensing Boiler

Brochure



R0000: A New Era of Commercial Boiler

A fresh approach to boiler design

The benefits of the new R0000 boilers ensure they are suitable for an extensive range of commercial heating systems, delivering high power in a compact size.



Built-in back-up

Thanks to a unique 'dual engine' design, R0000 boilers have built-in redundancy - creating a cascade system within one boiler. The two heat exchangers are capable of working independently from each other, ensuring that a system is never left without highly efficient heating.

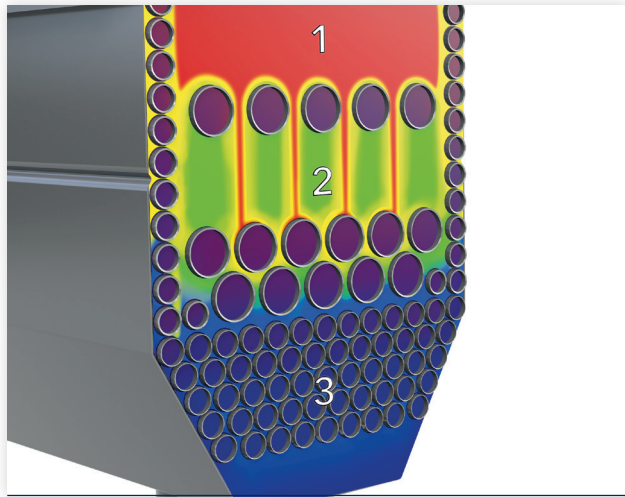

Designed for future standards

Within the R0000 is RENDAMAX's unique three zone heat exchanger technology.

1) NO_x zone: The formation of thermal NO_x is reduced to a minimum by low resistance and a short dwell time, as well as rapid cooling of the combustion gases to below 1,000 °C.

2) CO zone: By increasing resistance, the heat exchangers keep the combustion gas at over 600 °C for as long as possible to minimise the formation of carbon monoxide.

3) H₂O condensation zone: With small and densely arranged heat exchanger tubes, maximum heat transfer is achieved in this zone, ensuring optimum efficiency.



Plug & Play

By integrating main components within the boiler, such as the pump and non return valves, installation time, costs and space required are all significantly reduced. Thanks to the new HMI (Human Manual Interface) and a wide range of accessories, quick installations and commissioning become very simple.

Simple to service

All key components are accessible from the front of the boiler, making ongoing servicing and maintenance easy, while also reducing time on site.

Boiler Design



Stay connected and in control

R0000 is compatible with building management system protocols, including all common industry standards. This allows the boiler to be easily customised to a property's requirements, while still delivering optimal efficiencies.



R0000 — Exceeding Expectations

Engineered to excel

The R0000 delivers features that are unmatched in the market, thanks to a unique design and careful consideration of every detail.

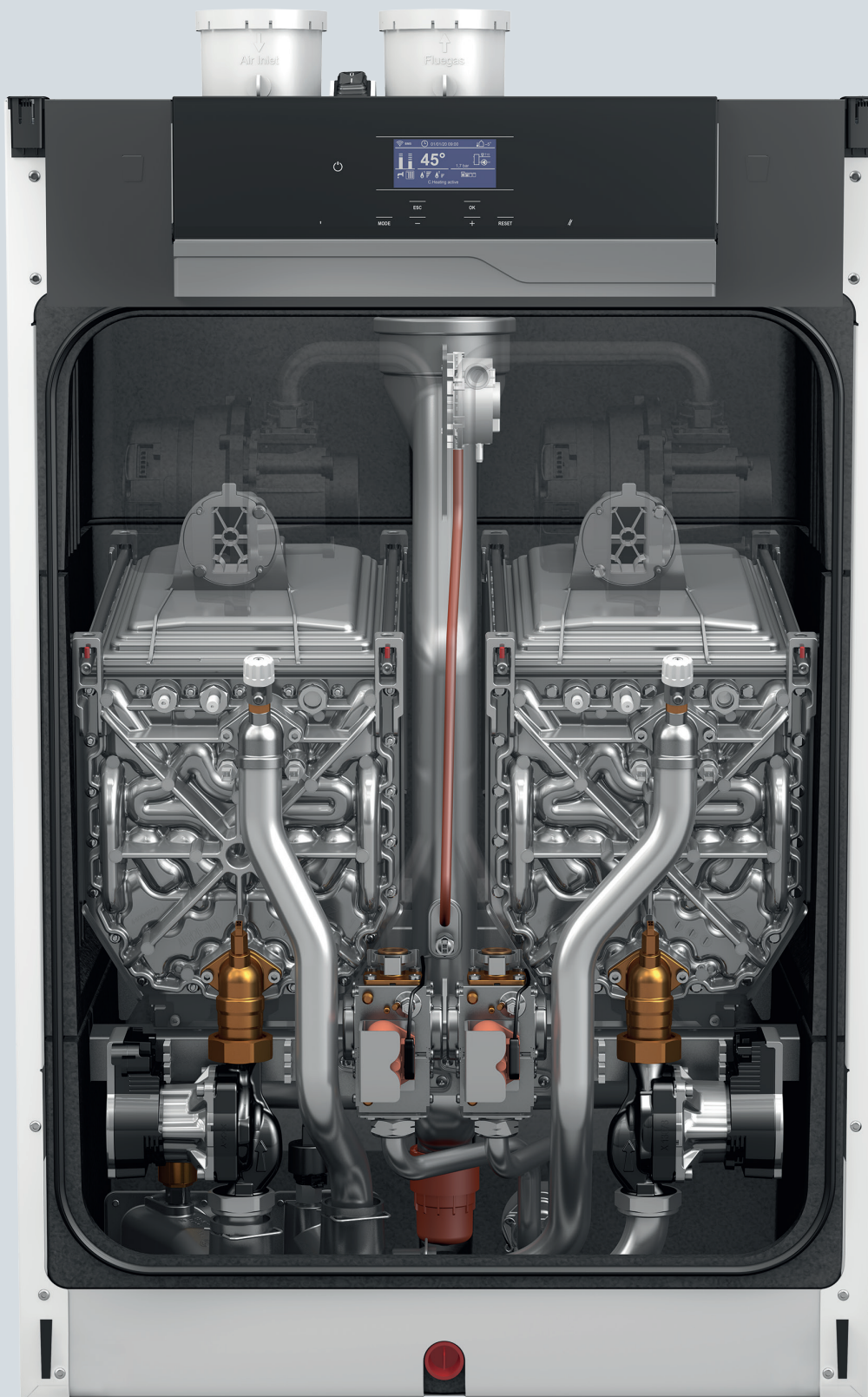

Key Features

Designed to deliver

R0000 has been manufactured to ensure its fundamental components operate to their maximum throughout the entire lifecycle of the unit.

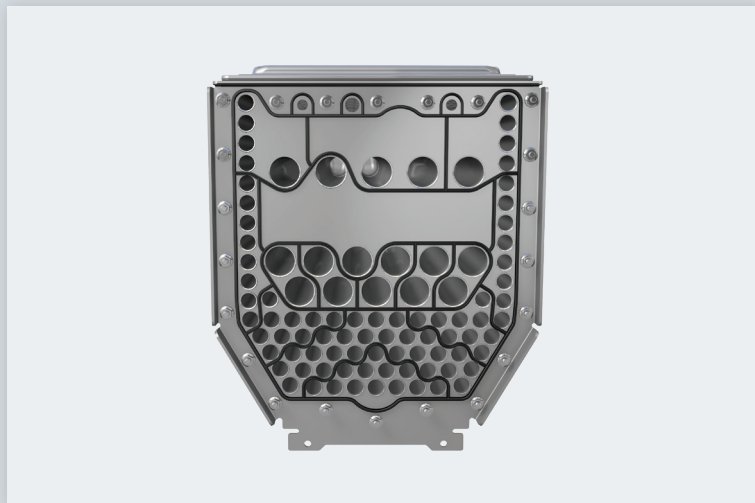

Efficient heat transfer

With specially designed hydraulic chambers, water turbulence within the boiler is optimised to ensure maximum heat transfer, while maintaining the lowest possible pressure drop.

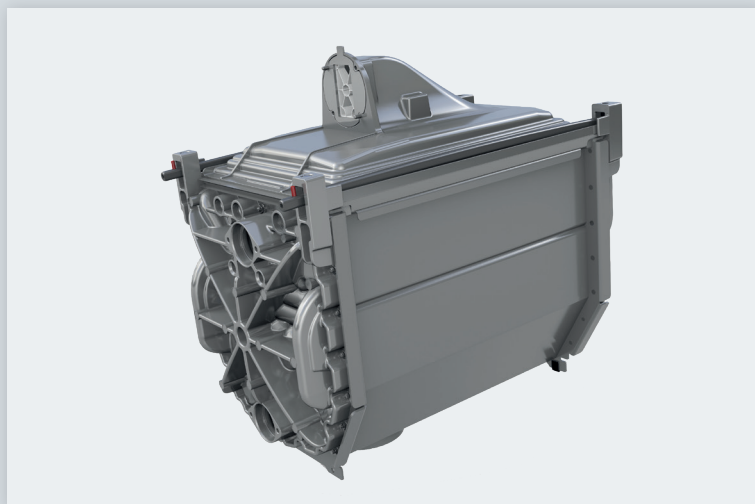

Robust and durable stainless-steel heat exchanger

By combining the highest quality materials with an improved heat exchanger design, which is based on 30 years of experience with the OSS heat exchanger, the R0000 delivers excellent efficiencies for the lifetime of the boiler, as well as incredibly low maintenance schedules. Specially designed smooth tubes ensure direct heat transfer, plus a down-firing arrangement avoids contamination of the heat exchanger.

High modulation range

A wide modulation range of up to 1:10 allows the R0000 to adapt to system requirements and maximise boiler efficiency.



Low heat loss and noise emissions

A completely expanded polypropylene insulated body encases the boiler to keep heat loss to an absolute minimum for improved boiler efficiency. Plus, the high quality casing minimises noise emissions to industry leading standards.

Cascade Portfolio

Extensive accessories with plug & play functionality

The R0000 is incredibly flexible and is available in either in-line or back-to-back configurations for up to eight boilers, delivering heat outputs up to 1,6 MW. The systems include all the components necessary to complete the primary heating circuit, with the cascade system specifically designed for quick, simple and effective installation.

In-line cascades



Max. Boilers in cascade		Max. Output
6 In-line		1 MW
Max. Dimensions		
Width mm	Height mm	Depth mm
4230	1700	755



Max. Boilers in cascade		Max. Output
8 In-line DUO		1,6 MW
Max. Dimensions		
Width mm	Height mm	Depth mm
6520	1700	755

Back-to-back cascades



Max. Boilers in cascade		Max. Output
4+4 B2B		1 MW
Max. Dimensions		
Width mm	Height mm	Depth mm
2830	1700	1510



Max. Boilers in cascade		Max. Output
4+4 B2B DUO		1,6 MW
Max. Dimensions		
Width mm	Height mm	Depth mm
3880	1700	1510

High Quality Components

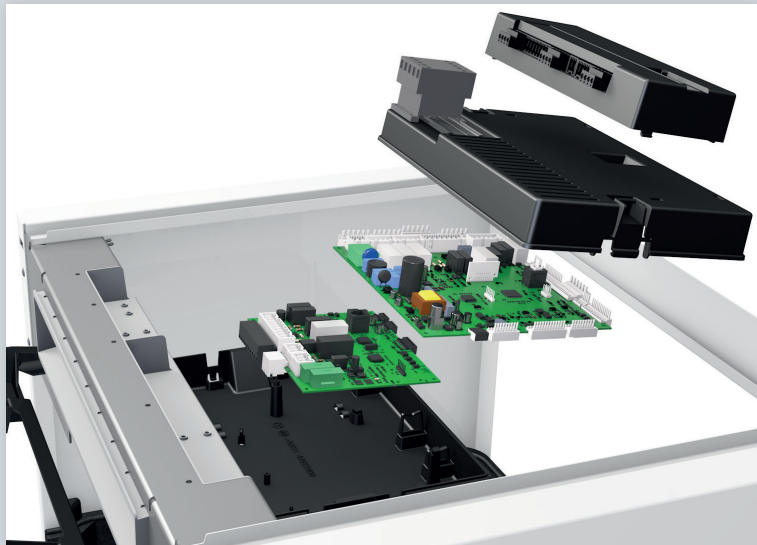

Smart interface with integrated cascade manager

The new control panel is positioned at the top of the boiler to guarantee maximum durability of electronic components, while also provide easy access to all boiler parameters. With a built-in cascade controller, the R0000 also allows quick and simple system optimisation, intuitive programming and full diagnostic capabilities. The cascade manager can support up to six mixed heating zones, thanks to two, three-zone clip-ins.

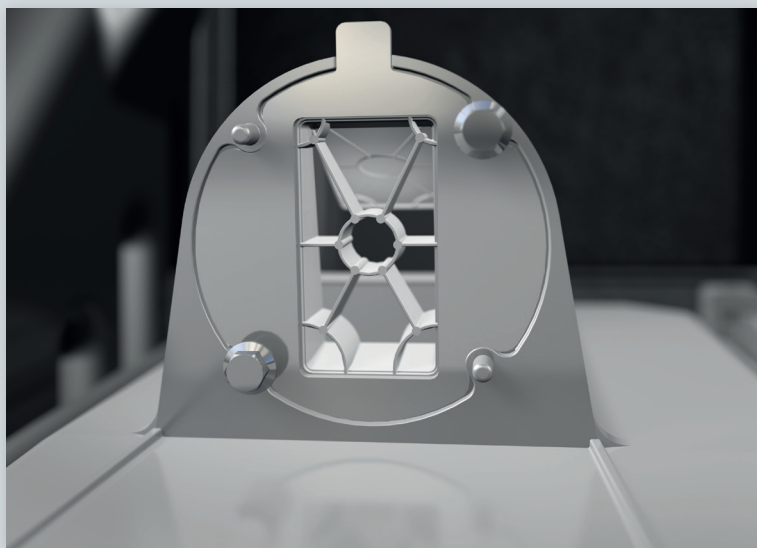

Integrated non-return valve

Built-in as standard, a non-return valve allows easy connection of the flue system, without loss of residual fan pressure.

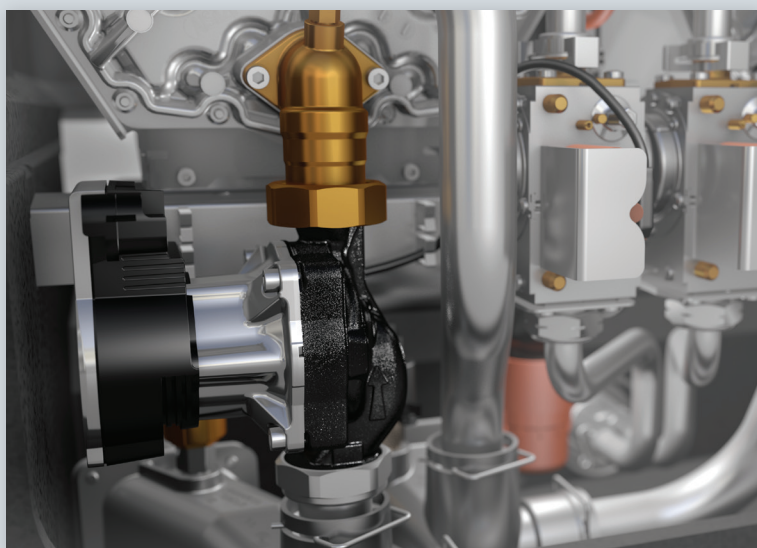

Smart and efficient built-in pump

Furthermore, the R0000 is able to communicate with the pump and receive feedback on its operation status. This built-in modulating pump is constantly monitoring the minimum flow rate through the boiler and is able to recognise sudden blockages, preventing damage, guaranteeing optimal working conditions and improving boiler efficiency.

Technical Data

R000		R0060	R0070	R0100	R0120	R0140	R0170	R0200
Nominal heat output at 80/60°C	kW	56,9	65,4	90,2	110,8	130,5	155,5	180,3
Minimum heat output at 80/60°C	kW	14,7	14,6	18,1	14,7	14,6	14,6	18,1
Nominal heat output at 50/30°C	kW	62,5	71,9	98,8	121,9	142,1	170,4	196,9
Minimum heat output at 50/30°C	kW	16,1	16,1	19,8	16,1	15,9	16,0	19,7
Nominal heat input Hi full load	kW	57,9	66,7	92,3	112,8	133,2	158,8	184,5
Minimum heat input Hi min. load	kW	14,88	14,88	18,45	14,88	14,88	14,88	18,45
Efficiency at 80/60°C Hi full load	%	98,2	98	97,7	98,2	98	97,9	97,7
Efficiency at 50/30°C Hi min. load	%	108,3	108,15	107,3	108,5	107,1	107,6	107
Efficiency at 40/30°C Hi min. load	%	108,5	108,35	107,6	108,7	107,3	107,9	107,3
Annual efficiency (NNG 40/30°C)	%	110,8	110,6	111,4	111	110,7	111,5	111,7
NOx class	-	6	6	6	6	6	6	6
NOx level (EN 15502) GCV	mg/kWh	21,7	22,4	22,7	22,7	23,7	22,6	23,6
Flue gas temperature at 80/60°C full load	°C	61,63	60,91	71,19	62	61	72,26	71
Max. permissible flue resistance	Pa	161	156	243	143	200	215	265
Water pressure max./min.	bar	6,0 / 0,7	6,0 / 0,7	6,0 / 0,7	6,0 / 0,7	6,0 / 0,7	6,0 / 0,7	6,0 / 0,7
Maximum temperature setpoint	°C	90	90	90	90	90	90	90
Maximum available head for system (ΔT 20K)	kPa	29,6	14,8	-	26,2	6,5	8,0	-
Maximum available head for system (ΔT 25K)	kPa	49,5	37,3	16,7	47,5	32,1	34,4	15,7
Water flow at ΔT=20K	m³/h	2,4	2,8	3,9	4,8	5,6	6,7	7,8
Nominal water flow at ΔT=25K	m³/h	2,0	2,3	3,1	3,8	4,5	5,4	6,2
Electrical connection	V	230	230	230	230	230	230	230
Power consumption speed controlled pump max.	W	75	75	87	150	150	174	174
Power consumption boiler max ErP (including pump)	W	126	137	120	314	418	464	450
Water content	l	9,3	9,3	13,9	16,8	16,8	21,3	25,8
Sound pressure level	dB(A)	50,5	54	49,3	56,3	59,3	56	52,4
Sound power level	dB(A)	61,5	65	60,3	67,3	70,3	67	63,4
Dimensions - Height x Width	mm	1050x530			1050x690			
Dimensions - Depth	mm	595		675	595		675	
Weight (empty)	kg	73	73	80	127	127	132	140
Energy efficiency class	-	A	A	-	-	-	-	-

Technical Drawings

Single engine

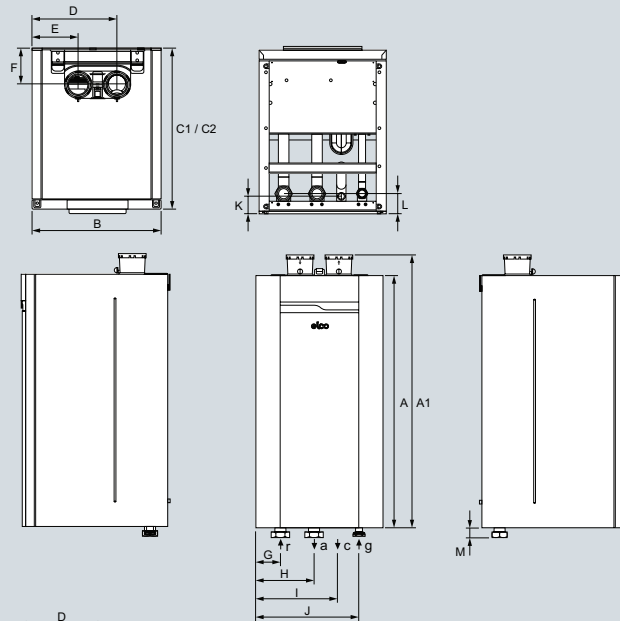

Double engine

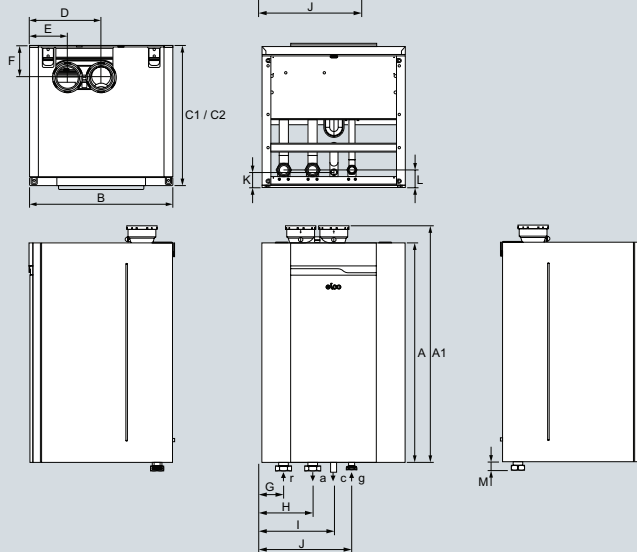

R000		R0060	R0070	R0100	R0120	R0140	R0170	R0200
Dimensions								
Boiler height (A)	mm	1050	1050	1050	1050	1050	1050	1050
Boiler height with flue connection (A1)	mm	1135	1135	1135	1135	1135	1135	1135
Boiler width (B)	mm	530	530	530	690	690	690	690
Boiler depth (C1/C2)	mm	595	595	675	595	595	675	675
Flue gas nozzle parallel (D)	mm	345	345	345	345	345	345	345
Air intake parallel (E)	mm	185	185	185	185	185	185	185
Flue gas nozzle (F)	mm	150	150	150	150	150	150	150
Boiler return connection (G)	mm	103	103	103	103	103	103	103
Boiler flow connection (H)	mm	243	243	243	243	243	243	243
Condensate connection (I)	mm	345	345	345	345	345	345	345
Gas connection (J)	mm	430	430	430	430	430	430	430
Condensate connection (K)	mm	60	60	60	60	60	60	60
Boiler return-flow-gas (L)	mm	75	75	75	75	75	75	75
Boiler return-flow-gas (M)	mm	25	25	25	25	25	25	25
Condensate connection (c)	mm	35	35	35	35	35	35	35
Parallel connection	mm	2x100	2x100	2x100	2x100	2x100	2x130	2x130
Boiler Flow (a) / Return (r) connection	-	2"	2"	2"	2"	2"	2"	2"
Gas connection (g)	-	1 1/4"	1 1/4"	1 1/4"	1 1/4"	1 1/4"	1 1/4"	1 1/4"

Rendamax – Quality Comes First

Rendamax is a leading manufacturer of high quality central heating and hot water equipment. Represented by dedicated companies/distributors worldwide, all products in the company's range offer substantial benefits, including superb efficiencies, ultra-low energy consumption and the lowest environmental impact.

Discover the full range of gas condensing commercial boilers



R600 EVO

- Floor standing
- 7 models (150 - 570 kW)
- Pre-mix modulating
- Highly efficient (up to 110 %)
- Stainless steel heat exchangers



R3456 EVO

- Floor standing
- 29 models (650 - 2.000 kW)
- Highly efficient (up to 109,7 %)
- Stainless steel heat exchangers



Phone: 0333 567 1121

Email: hello@viridis.energy

www.viridis.energy

Viridis Energy, 201 High St, Henley-in-Arden B95 5BA