

RENDAMAX R1000 Series

- GB** **Operating Manual**
authorized technicians only
- IT** **Istruzioni d'uso (Italian market)**
solo per tecnici autorizzati
- DE** **Betriebsanleitung**
für die autorisierte Fachkraft
- RU** **Руководство по монтажу и эксплуатации**
только для авторизованных технических специалистов
- ES** **Manual de uso**
solo para técnicos autorizados
- SL** **Priročnik za uporabo**
samo za pooblaščeno tehnično osebje
- GR** **Εγχειρίδιο λειτουργίας**
μόνο για εξουσιοδοτημένους τεχνικούς



Table of contents

Safety regulations	General regulations	3
	Intended use	3
	Standards and regulations	3
Product description	Functional description - R1000 SERIES.....	4-5
	Hydraulic circuit diagram	6
	Technical data / ERP data	7
	Dimensions.....	8-9
Delivery scope	Standard version / Accessories	10
	Cascade	11
	Cascade exampless	12-14
	Cascade accessories	15-16
Installation	Boiler transport	18
	Installation / Connections	18
	Hydraulics Circulation pumps	19
	Cascade floor standing in line	20
	Cascade floor standing back-to-back	21
	Connecting the boiler	22
	Cascade accessories	23
	Single boiler external	24
	Single boiler back-pack	24
	Dimensions headers, low loss headers and bends ...	25
	Water and hydraulic system	26
	Heating water quality	26
	System water additives	27
	Expansion vessel	28
	Gas line	29
	Condensate connection.....	30
	Hot water supply.....	31
	Air- / flue gas ducts.....	32-35
	Collective flue gas outlet	36-37
	Electrical connection	38-41
	Temperature sensors.....	42
	External controls.....	43
	eBus2 controls.....	44
	Wiring diagram	45-46
	Filling the system.....	47
Boiler setting	48
Operation	Description of display	49
	Description of display and keyboard	50
	Structure of the User Menu	51
	Change the settings (expert level).....	52
	Parameter listing	53-72
	Detail parameter description	73
	Function Thermoregulation.....	74
	Time programs Heating.....	75
	Automatic summer / winter changeover	76
Commissioning	Change the language on the screen	77
	Change the time and date	78
	Parameter adaption to the heating system.....	79-80
	Weather compensation.....	81
	Inspection	82
	Flue gas analysis.....	83-85
	Full load (Step 1/3).....	83
	Low load (Step 2/3)	84
	Adjustment on the gas valve (Step 3/3)	85
Maintenance	Decommissioning and maintenance works	86
	Inspection and maintenance interval.....	86
	Maintenance details	87-91
	Maintenance warning	91
	Inspection overview	92
	Maintenance overview.....	93
Errors	Error codes and fault finding	94-96
	Reset a Fault code	97
	View Error code History	98
	Disposal and recycling	99
Appendix	Sensor resistance	100
	Standard schemes	101-104
Declaration of conformity	105

Safety regulations

General regulations

Intended use

Standards and regulations

General regulations

This document contains important information with regard to safety and reliability of the installation, its commissioning and the operation of the R1000 boiler. All described activities must be carried out exclusively by authorized technicians.

Only OEM parts of the boiler manufacturer may be used; in contrary cases, our warranty and guarantee provisions are excluded.

Intended use

The R1000 is a condensing and modulating gas boiler, floor standing and is delivered with a pre-mix burner. The maximum target temperature of the boiler is 90°C.

Standards and regulations

All applicable standards (both European and national) must be observed during the installation and operation of the R1000 boiler, including:

- Local building regulations, with regard to the installation of heating facilities and waste gas exhaust systems;
- Regulations about a connection to the electrical utility network (mains);
- Regulations of the local gas utility;
- Standards and regulations concerning safety facilities for heating systems;
- Additional local laws/regulations, which are applicable to the installation and operation of heating systems.
- See the chapter "Commissioning", for those regulations applicable to heating water and warm water quality.

The R1000 boiler is CE-certified and conforms to the following European directives and standards:

- 92 / 42 / EEC
Efficiency of hot water heating systems
- 2016 / 426 / EU
Gas appliance regulation
- 2014 / 35 / EU
Low voltage directive
- 2014 / 30 / EU
EMC directive
- EN 15502-1
Requirements for gas-fired systems – Part 1: General requirements and tests
- EN 15502-2
Requirements for gas-fired systems

– Part 2-1: Type C such as B2, B3 and B5 with nominal calorific debit ≤ 1000 kW

- EN 55014-1 (2011) EMC – Requirements for household appliances, electrical tools and similar equipment – Part 1: Emissions
- EN 55014-2 (2008) EMC – Requirements for household appliances, electrical tools and similar equipment – Part 2: Safety - product family standard
- EN 61000-3-2 (2013) Electromagnetic compatibility (EMC) - Part 3-2: Framework conditions for current fluctuations (current drain 16 A per phase)
- EN 61000-3-3 (2014) Electromagnetic compatibility (EMC) - Part 3-3: Framework conditions for voltage fluctuations, voltage loss and flicker in public low-voltage networks, for equipment with a nominal 16 A current per phase, which are not subject to any special connection regulations.
- EN 60335-1 (2011) Household and similar electrical equipment - Safety - Part 1: General requirements
- EN 60335-2-102 (2006/A1-2010) Household and similar electrical equipment - Safety - Part 1: Special requirements for gas, oil and solid fuel-fired equipment with electrical connections

It is necessary that the currently valid local normatives will be observed.

UK:

British Standards

- BS 5440 - BS 6644 - BS 6891 - BS 7074 - BS 8552 - BS EN 60335 Pt1 - BS EN 12828

IGEM Documents

- IGE/UP/1&1A - IGE/UP/2 - IGE/UP/10

UK Regulation

- Clean Air Act 1993
- IEE Regulations
- Building Regulations
- Gas Safety (Installation & Use) Reg.

Other Guidance

- ICOM - BSRIA Documents BG29/2012
- BG50/2013 - CIBSE Guides (B1, C, F)

- HSE - INDG 436

Water Supply (Water Fittings) Regulations - 1999 schedule 2 - cI15.3 (UK)

Fluid category 3, when installed with plate heat exchanger due to product capacity and no pressurization unit needed. For more information contact local offices.



Incorrect operation can cause damage to the boiler and system components and has the potential to introduce hazards. Only persons with appropriate knowledge and qualifications, should be allowed to make adjustments to the boiler and associated equipment.



The equipment may not be used by children, by persons with a hindrance of bodily, mental or sensory capacities, or which insufficient experience and knowhow, unless they are supervised or have received corresponding instructions.



It must be ensured that children cannot play with the equipment.

Product description

R1000 Series

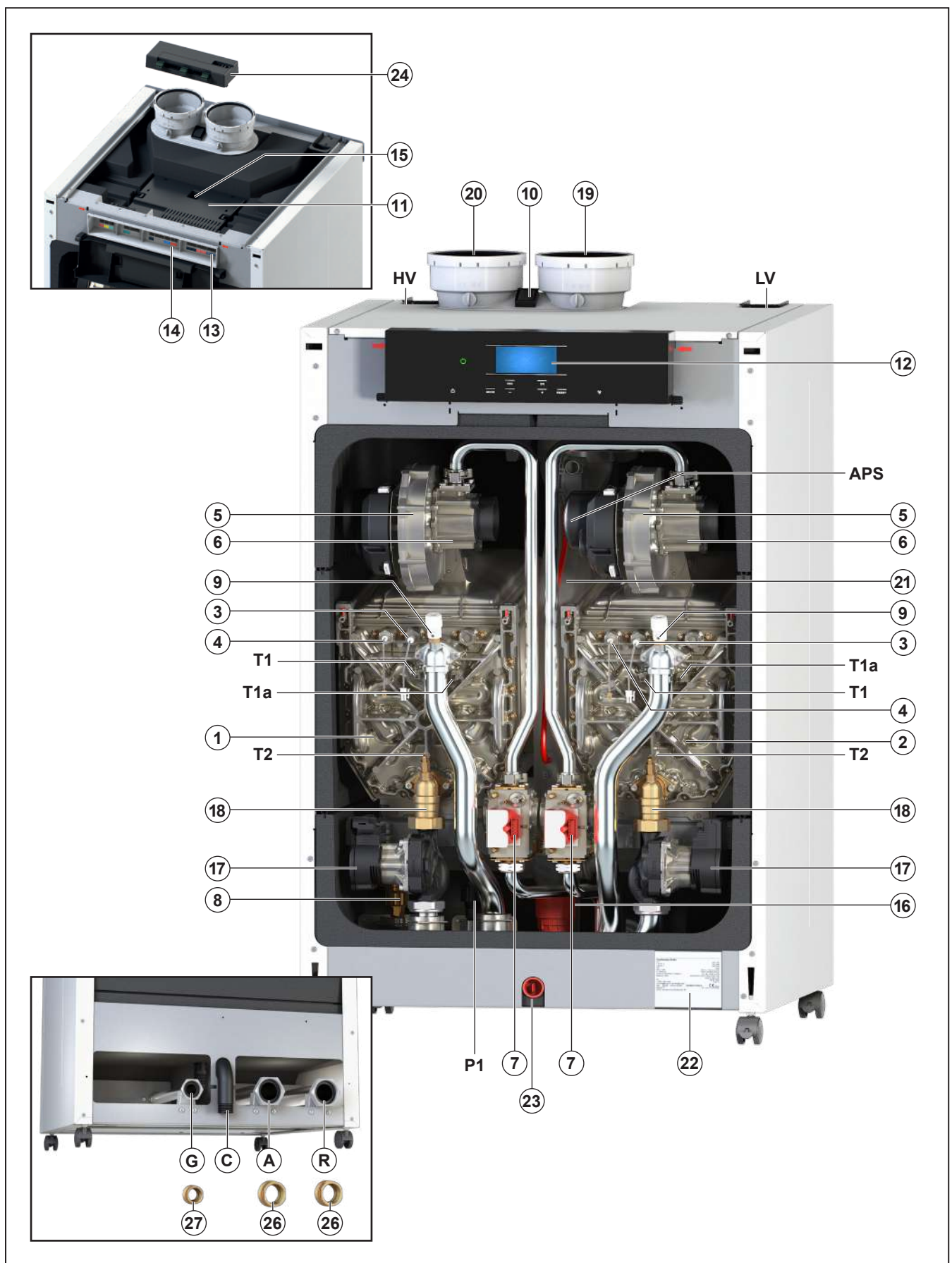

Product description

R1000 Series

Legend:

1. heat exchanger 1 (see table)
2. heat exchanger 2 (see table)
3. ignition electrode
4. detection electrode
5. fan unit
6. venturi
7. gas valve
8. automatic air vent
9. manual air vent
10. main switch 230V
11. boiler control unit
12. control unit HMI
13. connection terminal
14. connection terminal cascade bus communication
15. connection terminal pc
16. dirt collector
17. circulation pump
18. water no return valve
19. flue connection
20. air supply
21. collective flue pipe
22. information plate
23. drainage cap
24. clip 3 zone (optional)
25. air/flue connection concentric (optional for R1000 60-70-100-120-140)
26. water pipe connection 1 1/2" (optional)
27. gas pipe connection 1" (optional)

- T1 flow sensor
 T1a secondary flow sensor
 T2 return sensor
 P1 water pressure sensor
 APS Air Pressure Switch
 HV high voltage electrical supply
 LV low voltage electrical supply

- G gas pipe
 A flow pipe CH
 R return pipe CH
 C condensate drain pipe

Boiler type	Exchanger 1	Exchanger 2
60	iCon XL1	-
70	iCon XL1	-
100	iCon XL2	-
120	iCon XL1	iCon XL1
140	iCon XL1	iCon XL1
170	iCon XL2	iCon XL1
200	iCon XL2	iCon XL2

Product description

The R1000 is a condensing and modulating gas boiler with one or two pre-mix burners, floor standing. It is characterized by the following features:

- A large modulation range that guarantees a long burner service life, while minimizing standby losses, start-up emissions and material wear-and-tear.
- Flue gas temperature below 80°C
- Also suitable for room sealed conditions
- Control panel with all operational elements
- Microprocessor, with multi-functional display
- Automated ignition, with repetition and ionization monitoring
- Water pressure monitoring
- Energy-saving pump
- Stainless steel heat exchanger with smooth tube condenser
- Very maintenance-friendly
- Ready for weather-compensated control (accessory)
- Cascadecontroller up to 8 boilers
- External controls (accessory) by on/off , eBus or 0-10V
- Modern metal panelling, stove-enamelled

Functional description

The control unit modifies the heating performance to the current heating requirements, by changing the default values of the fan rotating speed. In this regard, the boiler flow temperature is continually measured via a sensor. In case of a deviation of the actual temperature from the target temperature, the control unit reacts immediately and adjusts the

RPM of the fan, and with that the boiler performance via the gas armature.

A deviation can be due to:

- A changed default value of the boiler temperature, via the ATG heating control unit
- A change on the outdoor temperature
- Request for Domestic Hot Water
- Changed heating curve

By means of the integration of the individual components in a system, and within the control range of the equipment, it is ensured that the boiler performance always corresponds to the actual heating requirements.

Delivery scope

The boiler, which has been assembled at the factory and is ready to use, is delivered in cardboard packaging.

The following is contained in the delivery scope of the R1000:

- Modulating high efficiency gas-fired boiler, 16.5 to 200kW
- High efficiency pump(s)
- Boiler/Cascade controller

Accessories:

- Boiler connection fittings
- Headers for 2 and 3 boilers
- Low loss headers up to 1600kW
- Plate heat exchanger up to 800kW
- Insulation packs
- Boiler frames for free standing units
- Exhaust pipe connection fittings
- Control for 3 extra heating zones
- Open bus translator

For detailed information see the chapter "delivery scope".

Product description

R1000 hydraulic circuit diagram

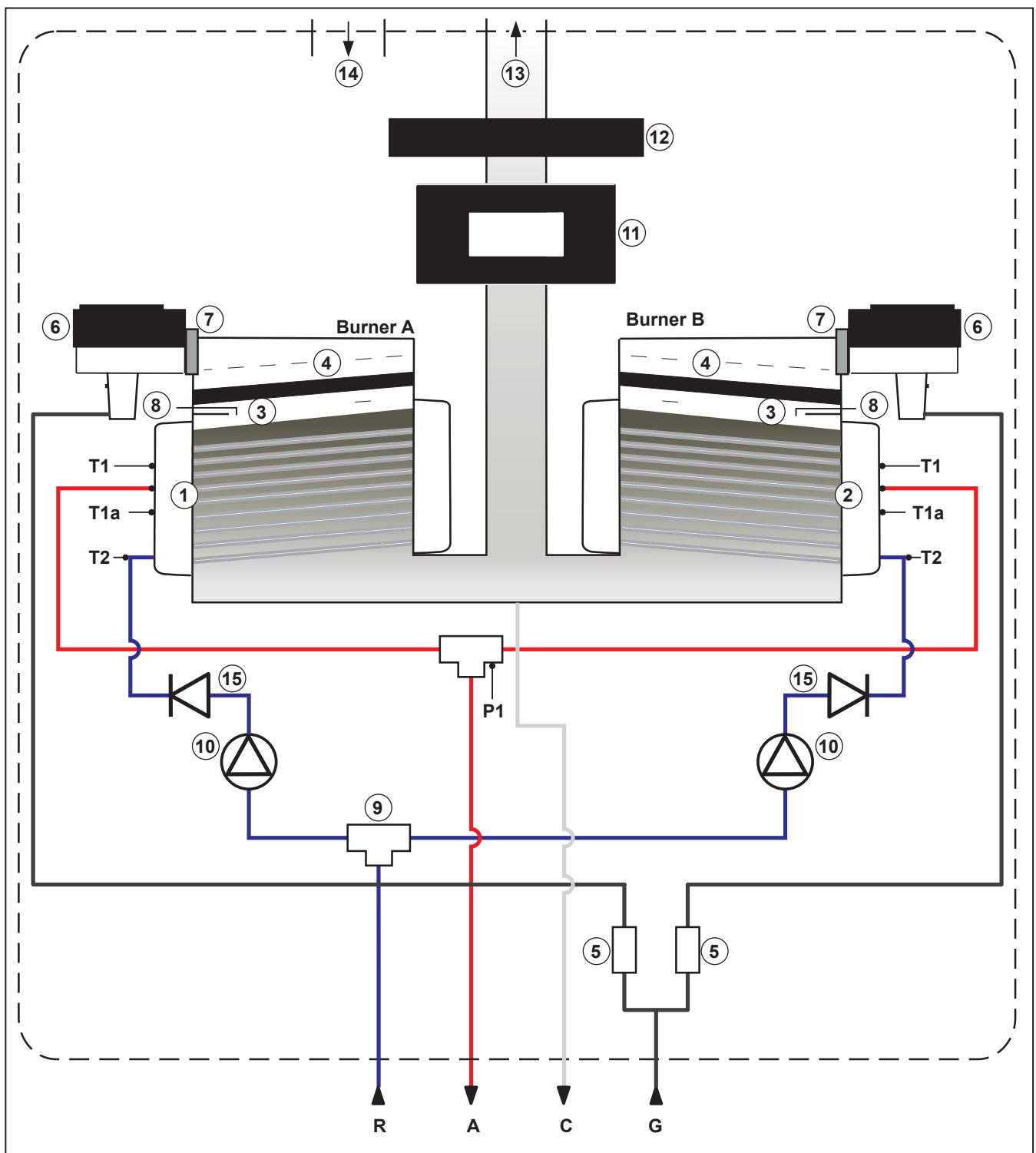

Legend:

- | | | |
|-------------------------------|---------------------------|---------------------------|
| 1 heat exchanger 1 = burner A | 8 venturi | T1 flow sensor |
| 2 heat exchanger 2 = burner B | 9 automatic air vent | T1a secondary flow sensor |
| 3 ignition | 10 circulation pump | T2 return sensor |
| 4 ceramic burner | 11 control unit HMI | P1 water pressure sensor |
| 5 gas valve | 12 burner control unit | G gas pipe |
| 6 fan | 13 flue gas outlet | A flow pipe CH |
| 7 flue non-return valve | 14 air inlet | R return pipe CH |
| | 15 water non return valve | C condensate drain pipe |

Product description

Technical data ErP data

Type R1000					R0060	R0070	R0100	R0120	R0140	R0170	R0200	
Permit					CE0063CT3449							
Category					GB: II2H3P							
Heat exchanger type					iConXL1	iConXL1	iConXL2	iConXL1	iConXL1	iConXL1	iConXL2	
Output	G20	Full load	80/60°C	kW	56,9	65,4	90,2	110,8	130,5	155,5	180,3	
			40/30°C	kW	62,6	72,0	99,0	122,2	142,4	170,9	197,4	
		Low load	80/60°C	kW	14,7	14,6	18,1	14,7	14,6	14,6	14,6	18,1
			40/30°C	kW	16,1	16,1	19,9	16,2	16,0	16,1	16,1	19,8
	G31	Full load	80/60°C	kW	56,9	65,4	90,2	110,8	130,5	155,5	180,3	
			40/30°C	kW	62,6	72,0	99,0	122,2	142,4	170,9	197,4	
		Low load	80/60°C	kW	23,3	23,2	34,3	23,3	23,2	23,2	23,2	34,3
			40/30°C	kW	25,6	25,6	37,7	25,7	25,3	25,5	25,5	37,6
Input	G20	Full load		kW	57,9	66,7	92,3	112,8	133,2	158,8	184,5	
				kW	14,9	14,9	18,5	14,9	14,9	14,9	18,5	
	G31	Full load		kW	57,9	66,7	92,3	112,8	133,2	158,8	184,5	
				kW	23,6	23,6	35,0	23,6	23,6	23,6	35,0	
Gas consumption	G20	Full load		m³/h	6,13	7,06	9,77	11,94	14,10	16,80	19,52	
				m³/h	1,57	1,57	1,95	1,57	1,57	1,57	1,95	
	G31	Full load		m³/h	2,36	2,72	3,76	4,60	5,43	6,47	7,52	
				m³/h	0,96	0,96	1,43	0,96	0,96	0,96	1,43	
Boiler efficiency	Full load	80/60°C	%	98,2	98,0	97,7	98,2	98,0	97,9	97,7		
		40/30°C	%	108,1	108,0	107,3	108,3	106,9	107,6	107,0		
	Low load	80/60°C	%	98,5	98,3	97,9	98,5	98,3	98,2	97,9		
		40/30°C	%	108,5	108,4	107,6	108,7	107,3	107,9	107,3		
Gas type				Natural gas or Propane gas								
CO ₂ natural gas		min./max	Vol. %	8,7 / 9,0								
CO ₂ propane gas		min./max	Vol. %	10,2 / 10,8								
O ₂ natural gas		min./max	Vol. %	5,3 / 4,8								
NOx class				6	6	6	6	6	6	6		
Max. flue gas temperature			80/60°C	62	61	71	62	61	72	71		
Mass flow of flue gas			kg/h	104,0	119,8	165,8	202,6	239,3	285,3	331,5		
Overpressure at boiler output		max	Pa	161	156	243	143	200	215	265		
Water volume in heating circuit		max	l	9,3	9,3	13,9	16,8	16,8	21,3	25,8		
Weight			kg	73	73	80	127	127	132	140		
Gas flow pressure - standard			mbar	20								
Gas flow-pressure min./max.			mbar	17 / 25								
Operating pressure of heating unit		min./max	bar	1* / 6 bar (*0,5bar: boiler shut off limit)								
Voltage/frequency		min./max	Volt/Hz	230 / 50								
Max. power consumption			W	145	155	250	260	375	428	430		
Power consumption part load			W	53	53	53	55	55	51	51		
Power consumption stand by			W	5	5	5	6,8	6,8	6,8	6,8		
Width / depth / height			mm	1100/530/595		1100/530/675		1100/690/595		1100/690/675		
Gas Coupling			R	Rp 1 1/4"								
Flow / Return Coupling			R	Rp 2"								
Fluegas Outlet		Diameter	DN	100	100	100	100	100	130	130		
Air inlet		Internal	in mm	100	100	100	100	100	130	130		
Condensate tube		External	in mm	35	35	35	35	35	35	35		

Type R1000				60	70	100	120	140	170	200	
ErP data according to 2010/30/EU and 811/2013/EU											
Seasonal room-heating energy efficiency class				A	A						
Nominal heat output				P _n (kW)	57	65	90	111	131	156	180
Seasonal room-heating energy efficiency class				η _s (%)	93	93	93	93	93	93	93
Annual energy consumption				Q _{HE} (GJ)	177	202	280	342	404	482	558
Noise output level, inside				L _{WA} (dB)	62	65	60	67	70	67	63
At rated heat output and high-temperature regime (80/60°C)				P4 (kW)	56,9	65,3	90,2	110,8	130,6	155,6	180,3
At 30 % of rated heat output and low-temperature regime (36/30°C)				P1 (kW)	19,0	21,8	30,2	37,0	43,7	52,0	60,4
At rated heat output and high-temperature regime (GCV)				η4 (%)	88,4	88,2	87,9	88,4	88,2	88,2	87,9
At 30 % of rated heat output and low-temperature regime (GCV)				η1 (%)	98,4	98,3	98,2	98,4	98,3	98,2	98,2
At full load				elmax (kW)	0,126	0,137	0,120	0,314	0,418	0,464	0,450
At part load				elmin (kW)	0,081	0,045	0,095	0,066	0,071	0,109	0,099
In standby mode				Psb (kW)	0,005	0,005	0,005	0,007	0,007	0,007	0,007
Standby heat loss				Pstby (kw)	0,086	0,086	0,075	0,079	0,079	0,100	0,141

Product description

Dimensions of R1000 single engine

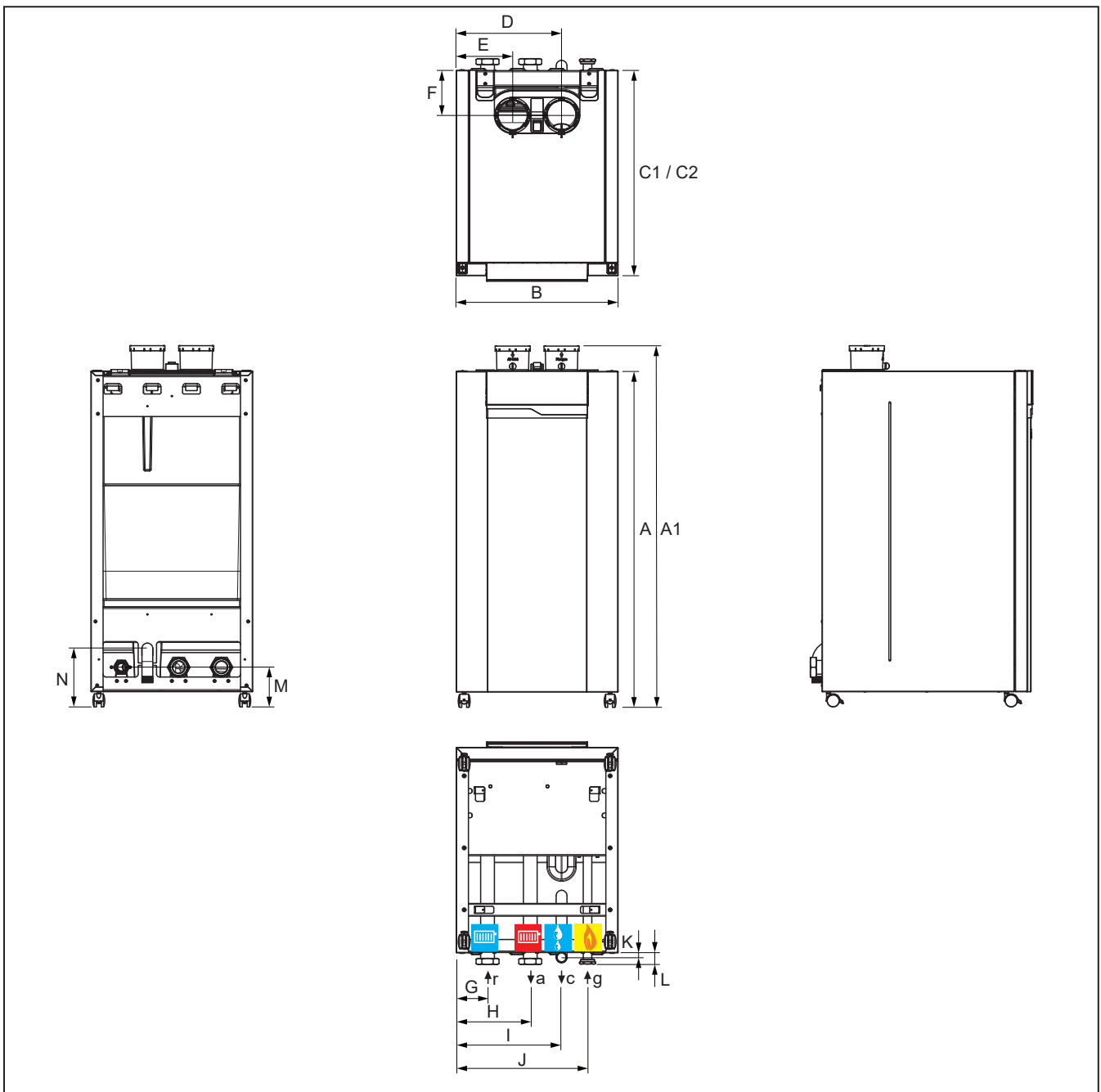

	Type R1000		60-70	100
A	Boiler height	mm	1100	1100
A1	Boiler height with flue connection	mm	1185	1185
B	Boiler width	mm	530	530
C1 / C2	Boiler depth	mm	595	675
D	Flue gas nozzle parallel	mm	345	345
E	Air intake parallel	mm	185	185
F	Flue gas nozzle	mm	150	150
G	Boiler return connection	mm	103	103
H	Boiler flow connection	mm	243	243
I	Condensate connection	mm	345	345
J	Gas connection	mm	430	430
K	Condensate connection	mm	15	15
L	Boiler return-flow-gas	mm	35	35
M	Boiler return-flow-gas	mm	130	130
N	Condensate connection	mm	190	190

Boiler connections				
	Type R1000		60-70	100
	Flue gas nozzle concentric	mm	100*	100*
	Air supply connector concentric	mm	150*	150*
	Parallel connection	mm	2x100	2x100
g	Gas connection		1 1/4"	1 1/4"
	Gas connection**		1" **	1" **
c	Condensate connection	mm	35	35
a	Boiler flow connection		2"	2"
	Boiler flow connection**		1 1/2" **	1 1/2" **
r	Boiler return connection		2"	2"
	Boiler return connection**		1 1/2" **	1 1/2" **

* with concentric adaptor (optional)

** with water/gas connection reduction kit (optional)

Product description

Dimensions of R1000 double engine

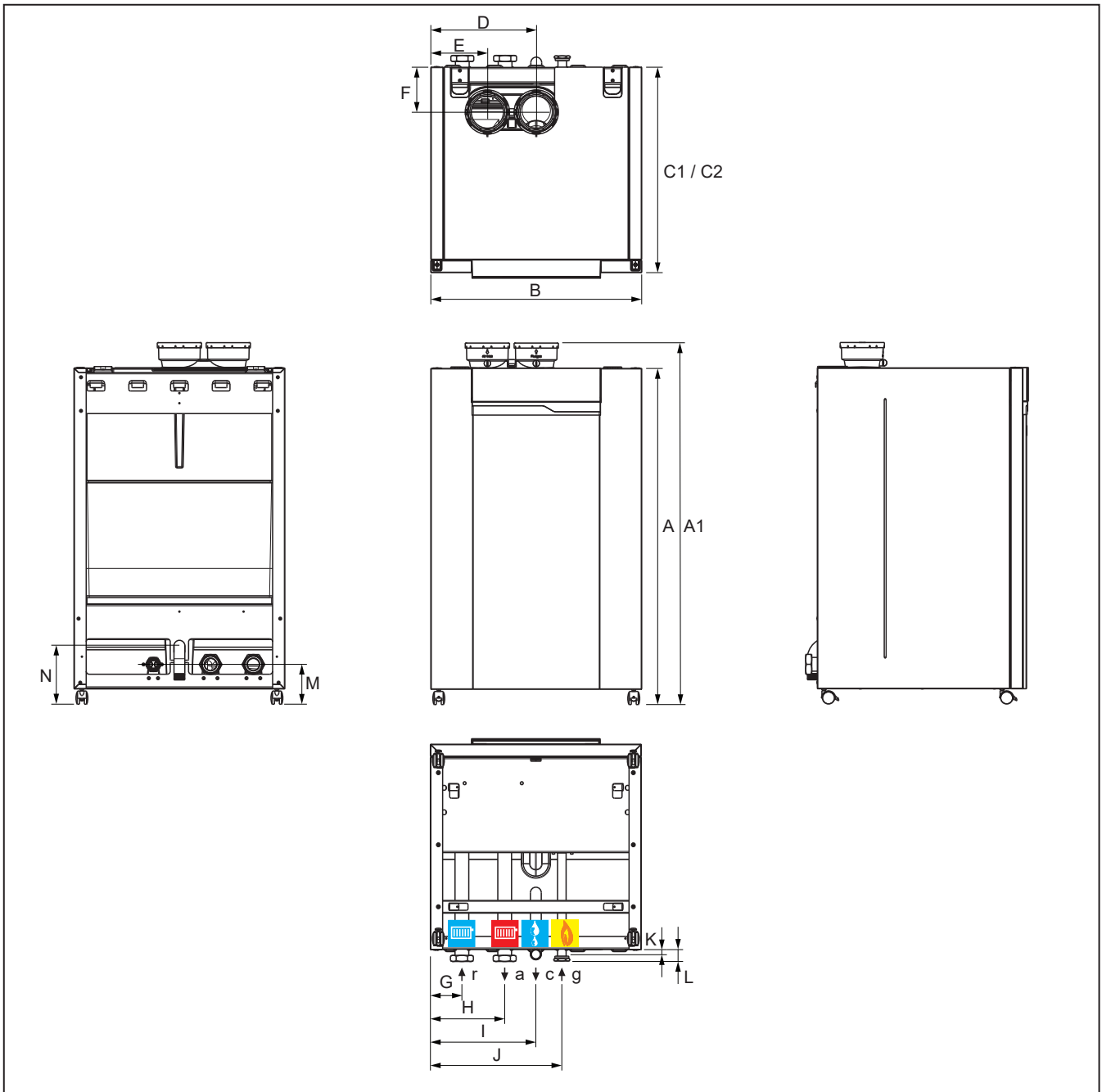

	Type R1000		120-140	170-200
A	Boiler height	mm	1100	1100
A1	Boiler height with flue connection	mm	1185	1185
B	Boiler width	mm	690	690
C1 / C2	Boiler depth	mm	595	675
D	Flue gas nozzle parallel	mm	345	345
E	Air intake parallel	mm	185	185
F	Flue gas nozzle	mm	150	150
G	Boiler return connection	mm	103	103
H	Boiler flow connection	mm	243	243
I	Condensate connection	mm	345	345
J	Gas connection	mm	430	430
K	Condensate connection	mm	15	15
L	Boiler return-flow-gas	mm	35	35
M	Boiler return-flow-gas	mm	130	130
N	Condensate connection	mm	190	190

Boiler connections				
	Type R1000		120-140	170-200
	Flue gas nozzle concentric	mm	100*	-
	Air supply connector concentric	mm	150*	-
	Parallel connection	mm	2x100	2x130
g	Gas connection		1 1/4"	1 1/4"
	Gas connection**		1" **	1" **
c	Condensate connection	mm	35	35
a	Boiler flow connection		2"	2"
	Boiler flow connection**		1 1/2" **	1 1/2" **
r	Boiler return connection		2"	2"
	Boiler return connection**		1 1/2" **	1 1/2" **

* with concentric adaptor (optional)

** with water/gas connection reduction kit (optional)

Delivery scope

Standard version Accessories and Cascade

Standard version

The delivery scope of a boiler consists of the following components:

Components		Packaging type
Completely assembled and tested boiler	1	In cardboard box
Roll off rail	2	In boiler packaging
Installation manual R1000	1	In document bag in boiler packaging
ERP label (only R1000 60-70)	1	
condense pipe	1	

Accessories

The following accessories can be ordered:

- Flue gas pipes
- Air filter
- Cascade hydraulics (see following pages)
- Boiler frames (see following pages)
- 3-way valve set
- Outdoor sensor, tank sensor
- T10 flow sensor
- Control for 3 extra heating zones
- Modbus/LON/BACKNET/KNX bus translator
- Water/gas connection kit
- Gas filter
- Min gas pressure switch
- LPG conversion kit
- Plate heat exchanger kit
- Low loss header kit

Listed accessory parts have been constructed or selected especially for the R1000 boiler, which means they are very easy to install (plug and play). You can compose your own system solution, by selecting the accessory combination that fits your needs. For details and prices, please contact Rendamac.

In case of cascade configuration, accessories that require an electrical connection should be connected with Master boiler (with the only exception of tank probe and Clip in, that can be connected also to other boiler).

Cascade

In principle any combination is possible. The selection can include models with different outputs, if this meets the installation requirements. Including boilers with common outputs assists with sharing load and run times of individual appliance.

The capacity of the hydraulic pipes, gas line and low loss header are adjusted to the selected overall demand.

When installing a single R1000 boiler the use of a low loss header is strongly suggested.

When installing a cascaded R1000 boilers: the use of a low loss header adjusted to the set demand is mandatory; the realization of an additional bypass is not allowed; water collector should be realized in a the dimension of DN65 or DN100 (according to cascade output). Rendamac supplies low loss header versions, which are suitable for a maximum demand of 1600kW.

Product description

R1000 Cascade

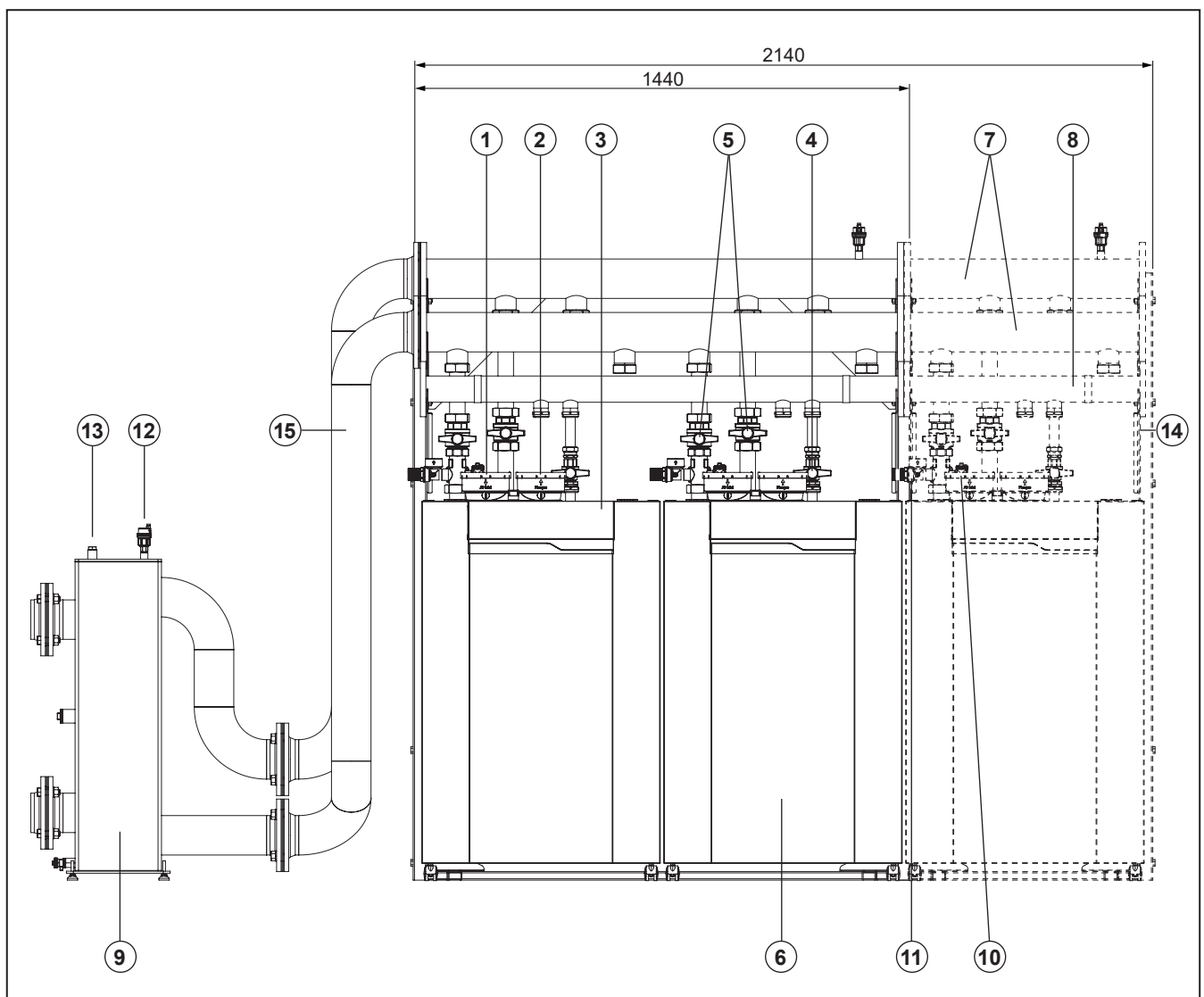

Legend:

1. Air supply
2. Flue/Air supply
3. Cascade manager

Accessories:

4. Gas isolation valve
5. Service valves flow and return
6. Non-return valve
7. Flow/return header
8. Gas line
9. Low loss header
10. Safety valve 3 or 6 bar
11. Fill and drain valve
12. Automatic air vent low loss header
13. Pocket for temperature sensor T10
14. Frame
15. LLH connection pipe LEFT or RIGHT side*

*Low loss header can be installed on left or right side of the cascade using proper left or right connection pipe kit.

Cascade possibilities

The Rendamac R1000 cascade can be mounted in 2 ways:

- **Floor-standing in line**
All boilers standing alongside one another.
- **Floor-standing back-to-back**
All boilers standing back-to-back

Product description

R1000 Cascade examples floor standing in line

R1000 2 boilers floor standing in line

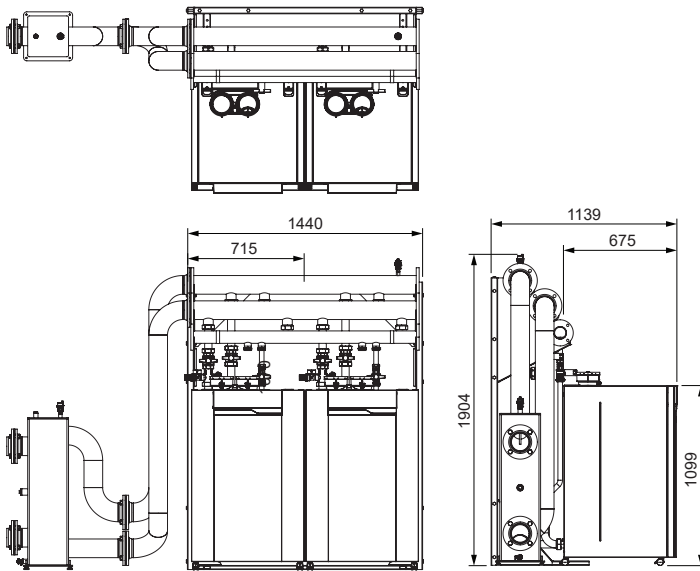

R1000 3 boilers floor standing in line

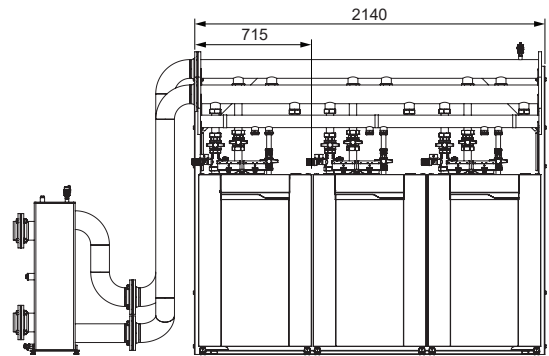

R1000 5 boilers floor standing in line

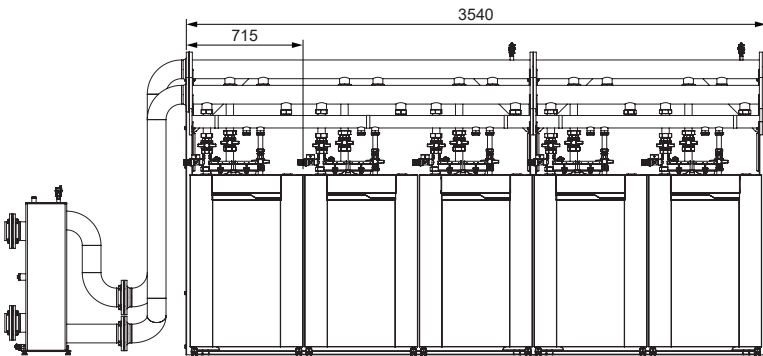

R1000 8 boilers floor standing in line

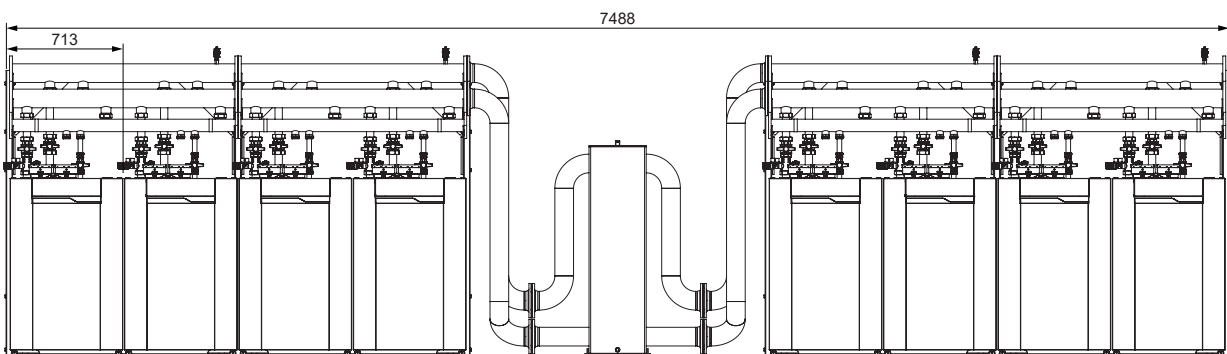

Product description

R1000 Cascade examples floor standing back-to-back

R1000 3 boilers floor standing back-to-back

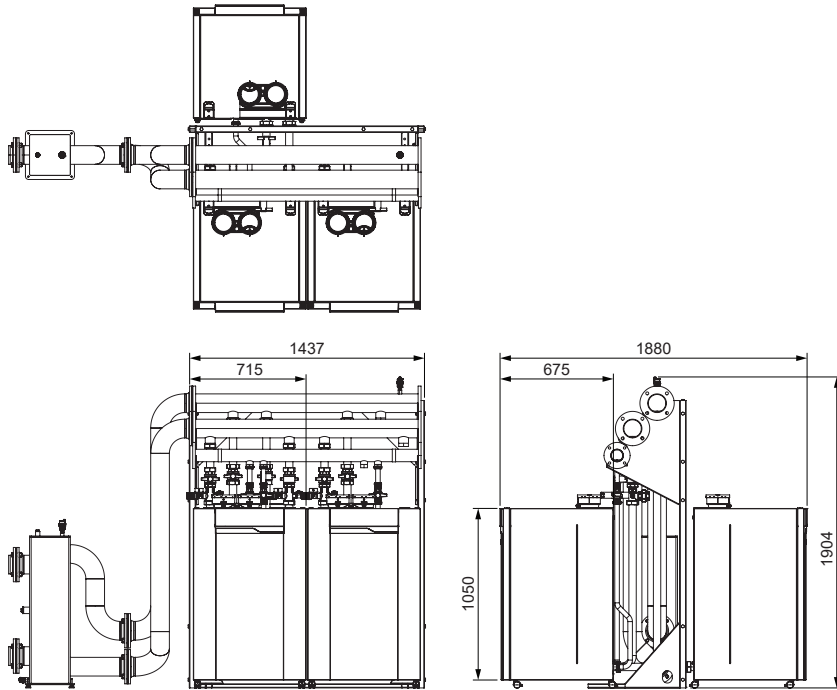

R1000 4 boilers floor standing back-to-back

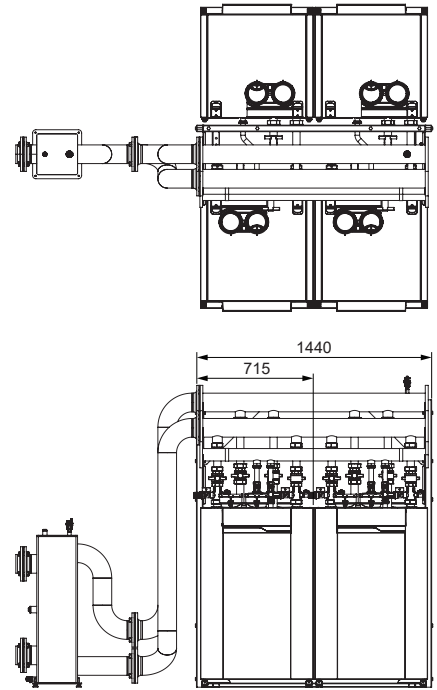

R1000 6 boilers floor standing back-to-back

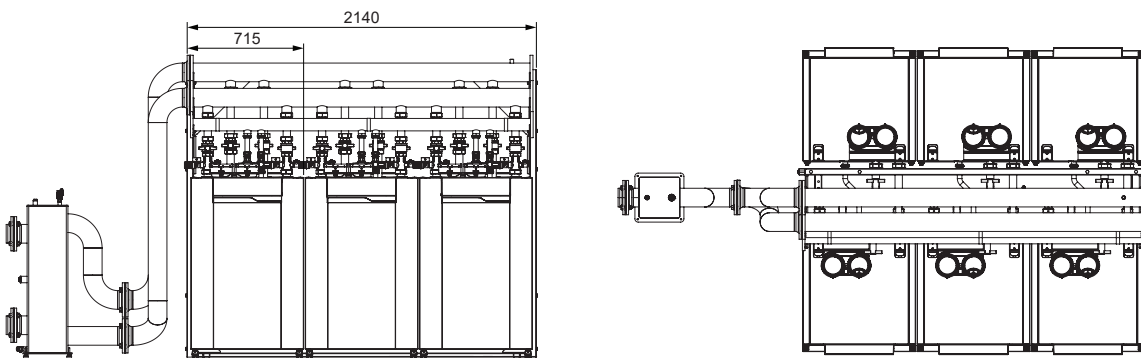

R1000 8 boilers floor standing back-to-back

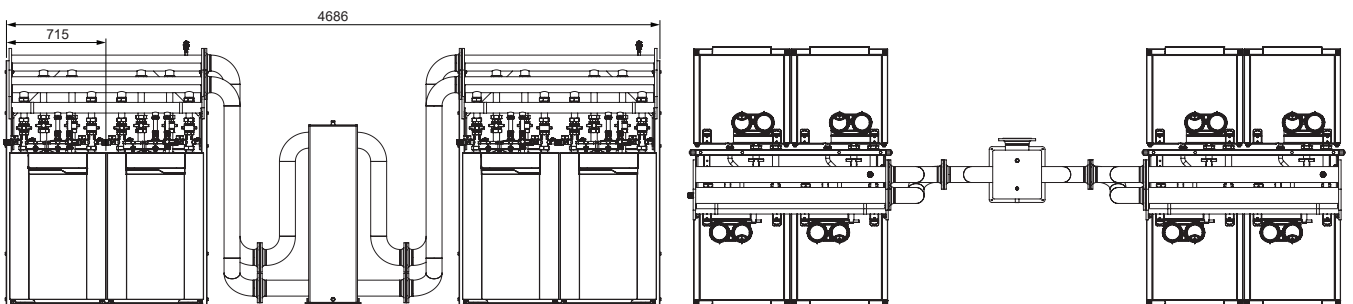

Product description

R1000 Cascade accessories

FG codes	Description	Single	Boiler					Cascade FS in line	Cascade FS B2B	Power size
			60/70	100	120/140	170	200			
3905101	MIN. GAS PRESSURE SWITCH - BOILER	x	x	x	x	x	x			
3905102	MIN. GAS PRESSURE SWITCH - CASCADE							x	x	0-1600
3905103	ROOM FAN + EXT. GAS VALVE	x	x	x	x	x	x			
3905104	GAS FILTER 70-100-140	x	x	x	x					
3905105	GAS FILTER 170-200	x				x	x			
3905115	AIR FILTER Ø100	x	x	x	x					
3905116	AIR FILTER Ø130	x				x	x			
3905117	WATER-GAS CONNECTION KIT	x	x	x	x	x	x			
3905120	REMOCON MODBUS-LON	x	x	x	x	x	x	x	x	0-1600
3905121	REMOCON MODBUS-BACNET	x	x	x	x	x	x	x	x	0-1600
3905122	REMOCON MODBUS	x	x	x	x	x	x	x	x	0-1600
3905123	REMOCON MODBUS-KNX	x	x	x	x	x	x	x	x	0-1600
3905124	CLIP IN ZONE MANAGER	x	x	x	x	x	x	x	x	0-1600
3905045	Low loss header-DHW sensor	x	x	x	x	x	x	x	x	0-1600
3905127	Outdoor sensor	x	x	x	x	x	x	x	x	0-1600
3905128	Zone sensor	x	x	x	x	x	x	x	x	0-1600
3905136	INSULATION COLLECTOR DN65/DN100 (L=1B)							x	x	0-1600
3905137	CASCADE DEAREATOR							x	x	0-1600
3905138	GAS FILTER DN65							x	x	0-1600
3905026	FLANGE KIT DN65 WATER							x	x	0-465
3905027	FLANGE KIT DN100 WATER							x	x	0-1600
3905029	FLANGE KIT DN65 GAS							x	x	0-1600
3905038	LASFLENS SET DN100 A/R + GAS DN 65							x	x	0-1600
3905126	welding flange DN150 water+DN65 gas							x	x	0-1600
3905150	KIT BOILER CH	x	x	x	x	x	x			
3905151	KIT BOILER DHW	x	x	x	x	x	x			
3905164	CONNECTION KIT FS CH FRONT							x		0-1600
3905165	CONNECTION KIT FS CH BACK								x	0-1600
3905166	CONNECTION KIT FS DHW							x		0-1600
3905168	COLLECTOR ASM FLOW/RETURN DN100 2B LINE/4B B2B FS							x	x	0-1600
3905169	COLLECTOR ASM FLOW/RETURN DN100 3B LINE/6B B2B FS							x	x	0-1600
3905171	BACK PACK SE Low loss header dT10-20K FS	x	x	x						
3905172	BACK PACK DE Low loss header dT10-20K FS	x			x	x	x			
3905173	BOILER Low loss header dT10-20K	x	x	x	x	x	x			
3905175	Insulation BOILER Low loss header dT10-20K	x	x	x	x	x	x			
3905034	Low loss header DN100							x	x	0-960
3905036	Bend 90° DN100							x	x	0-1600
3905174	Insulation Bend 90° DN100							x	x	0-1600
3905176	Low loss header DN100 DUO kit							x	x	960-1600
3905177	Insulation LLH header DN100							x	x	0-960
3905178	Connection kit FS cascade LLH LEFT							x	x	0-1600
3905179	Connection kit FS cascade LLH RIGHT							x	x	0-1600
3905180	BACK PACK SE Plate HEAT EXCH. dT10K	x	x	x						
3905181	BACK PACK DE Plate HEAT EXCH. dT10K	x			x	x	x			
3905182	BACK PACK SE Plate HEAT EXCH. dT15K	x	x	x						
3905183	BACK PACK DE Plate HEAT EXCH. dT15K	x			x	x	x			
3905184	BACK PACK SE Plate HEAT EXCH. dT20K	x	x	x						
3905185	BACK PACK DE Plate HEAT EXCH. dT20K	x			x	x	x			
3905186	BOILER SE Plate HEAT EXCH. dT10K	x	x	x						
3905187	BOILER DE Plate HEAT EXCH. dT10K	x			x	x	x			
3905188	BOILER SE Plate HEAT EXCH. dT15K	x	x	x						
3905189	BOILER DE Plate HEAT EXCH. dT15K	x			x	x	x			
3905190	BOILER SE Plate HEAT EXCH. dT20K	x	x	x						
3905191	BOILER DE Plate HEAT EXCH. dT20K	x			x	x	x			
3905192	BOILER Connection kit Plate heat exch.	x	x	x	x	x	x			
3905193	BOILER Expansion vessel kit	x	x	x	x	x	x			
3905194	CASCADE Plate HEAT EXCH. dT10K		x	x	x	x	x	x	x	
3905195	CASCADE Plate HEAT EXCH. dT15K		x	x	x	x	x	x	x	
3905196	CASCADE Plate HEAT EXCH. dT20K		x	x	x	x	x	x	x	

Product description

R1000 Cascade accessories

FG codes	Description	Single	Boiler					Cascade FS in line	Cascade FS B2B	Power size
			60/70	100	120/140	170	200			
3905197	CASCADE PHE Connection kit							x	x	0-1600
3905265	CASCADE PHE Connection kit DN100							x	x	0-1600
3905198	CASCADE FLUE KIT DN150 LINE		x	x	x			x	x	
3905199	FLUE SIPHON SET DN150		x	x	x			x	x	
3905200	CASCADE FLUE KIT DN200 LINE		x	x	x			x	x	
3905201	FLUE SIPHON SET DN200		x	x	x	x	x	x	x	
3905202	CASCADE FLUE KIT DN150 B2B		x	x	x			x	x	
3905203	CASCADE FLUE KIT DN200 B2B		x	x	x			x	x	
3905204	FLUE PIPE PP 100MM L=0.5M	x	x	x	x					
3905205	FLUE PIPE PP 100MM L=1.0M	x	x	x	x					
3905206	FLUE BEND PP 90 DEGR 100MM	x	x	x	x					
3905207	FLUE BEND PP 45 DEGR 100MM	x	x	x	x					
3905208	FLUE SUPPORT ELBOW PP 90 DEGR 100MM	x	x	x	x					
3905209	FLUE T-PIECE PP 100MM + COVER	x	x	x	x					
3905210	FLUE SIPHON SET DN100	x	x	x	x					
3905211	FLUE EXPANDER PP 100-150MM	x	x	x	x					
3905212	FLUE CHIMNEY CAP + AIR VENT 100MM	x	x	x	x					
3905213	FLUE WALL BRACKET 100MM	x	x	x	x					
3905214	FLUE WALL PLATE 100MM	x	x	x	x					
3905215	FLUE VENTILATION GRATE 100MM-200MM	x	x	x	x					
3905216	FLUE PIPE PP 150MM L=0.5M		x	x	x	x	x	x	x	
3905217	FLUE PIPE PP 150MM L=1.0M		x	x	x	x	x	x	x	
3905218	FLUE BEND PP 90 DEGR 150MM		x	x	x	x	x	x	x	
3905219	FLUE BEND PP 45 DEGR 150MM		x	x	x	x	x	x	x	
3905220	FLUE BEND PP 15 DEGR 150MM		x	x	x	x	x	x	x	
3905221	FLUE EXPANDER PP 100-200MM		x	x	x	x	x	x	x	
3905222	FLUE EXPANDER PP 150-200MM		x	x	x	x	x	x	x	
3905223	FLUE T-PIECE PP 150MM + COVER		x	x	x	x	x	x	x	
3905224	FLUE WALL BRACKET 150MM		x	x	x	x	x	x	x	
3905225	FLUE WALL PLATE 150MM		x	x	x	x	x	x	x	
3905226	FLUE SUPPORT ELBOW PP 90 DEGR 150MM		x	x	x	x	x	x	x	
3905227	FLUE SUPPORT STRIP		x	x	x	x	x	x	x	
3905228	FLUE SPACER BRACKET 150MM 2PCS		x	x	x	x	x	x	x	
3905229	FLUE CHIMNEY CAP + AIR VENT 150MM		x	x	x	x	x	x	x	
3905230	FLUE CHIMNEY CAP EXT. 150MM		x	x	x	x	x	x	x	
3905231	FLUE ROOF TERMINAL PP 150MM		x	x	x	x	x	x	x	
3905232	WEATHER SLATE FLAT ROOF 150MM		x	x	x	x	x	x	x	
3905233	FLUE PIPE PP 200MM L=0.5M		x	x	x	x	x	x	x	
3905234	FLUE PIPE PP 200MM L=1.0M		x	x	x	x	x	x	x	
3905235	FLUE BEND PP 90 DEGR 200MM		x	x	x	x	x	x	x	
3905236	FLUE BEND PP 45 DEGR 200MM		x	x	x	x	x	x	x	
3905237	FLUE BEND PP 15 DEGR 200MM		x	x	x	x	x	x	x	
3905238	FLUE T-PIECE PP 200MM + COVER		x	x	x	x	x	x	x	
3905239	FLUE WALL BRACKET 200MM		x	x	x	x	x	x	x	
3905240	FLUE WALL PLATE 200MM		x	x	x	x	x	x	x	
3905241	FLUE SUPPORT ELBOW PP 90 DEGR 200MM		x	x	x	x	x	x	x	
3905242	FLUE SPACER BRACKET 200MM 2PCS		x	x	x	x	x	x	x	
3905243	FLUE CHIMNEY CAP + AIR VENT 200MM		x	x	x	x	x	x	x	
3905244	FLUE CHIMNEY CAP EXT. 200MM		x	x	x	x	x	x	x	
3905245	FLUE ROOF TERMINAL PP 200MM		x	x	x	x	x	x	x	
3905246	WEATHER SLATE FLAT ROOF 200MM		x	x	x	x	x	x	x	
3905247	FLUE ROOF TERMINAL CONC. PP 100/150MM	x	x	x	x					
3905248	FLUE PIPE PP CONC 100/150MM L=0.5M	x	x	x	x					
3905249	FLUE PIPE PP CONC 100/150MM L=1.0M	x	x	x	x					
3905250	FLUE BEND PP 90 DEGR CONC 100/150MM	x	x	x	x					
3905251	FLUE BEND PP 45 DEGR CONC 100/150MM	x	x	x	x					
3905252	FLUE SUPPORT ELBOW PP 90 DEGR CONC 100/150MM	x	x	x	x					
3905253	FLUE T-PIECE PP CONC 100/150MM + COVER	x	x	x	x					
3905254	FLUE SIPHON SET CONC 100/150MM	x	x	x	x					
3905255	FLUE CHIMNEY CAP + AIR VENT CONC 100/150MM	x	x	x	x					
3905256	FLUE WALL BRACKET CONC 100/150MM	x	x	x	x					
3905257	FLUE WALL PLATE CONC 100/150MM	x	x	x	x					

Product description

R1000 Cascade accessories

FG codes	Description	Single	Boiler					Cascade FS in line	Cascade FS B2B	Power size
			60/70	100	120/140	170	200			
3905259	FLUE WALL TERMINAL PP CONC 100/150MM	x	x	x	x					
3905260	FLUE ADAPTER PAR - CONC 100/100-100/150	x	x	x	x					
3905261	ADAPTOR Ø100-110 FLUE/AIR	x	x	x	x					
3905262	FLUE EXPANDER 130-150MM	x				x	x	x	x	
3905263	FLUE EXPANDER 130-200MM	x				x	x	x	x	
3905264	FLUE REDUCER 130-100MM	x				x	x			
3905285	LPG kit 60-70	x	x							
3905286	LPG kit 100	x		x						
3905287	LPG kit 120-140	x			x					
3905288	LPG kit 170	x				x				
3905289	LPG kit 200	x					x			

Installation

Boiler transport

The R1000 is a fully equipped compact heating system, which has been pre-set and tested at the factory.

The package dimensions for all appliances are:

Width 750mm

Height 1200mm

Depth 800mm

This makes it possible to transport all models in one piece through a normal door.

The boiler can be moved using a fork-lift or pallet truck. Unpacking instructions are printed on the cardboard box. Please follow the proposed steps.

Disassembly of panelling

The appliance casing panels can be easily removed and this is recommended while the appliance is being installed. This limits the potential for damage to occur.

Handling and carrying precautions:

- Wear protective clothing and gloves to protect from any sharp edges.
- The boiler should be handled with its pallet using a fork lifter, wheels can be used for final positioning.

Panelling should be attached and secured with the supplied screw, after assembly of the boiler, or after maintenance works.

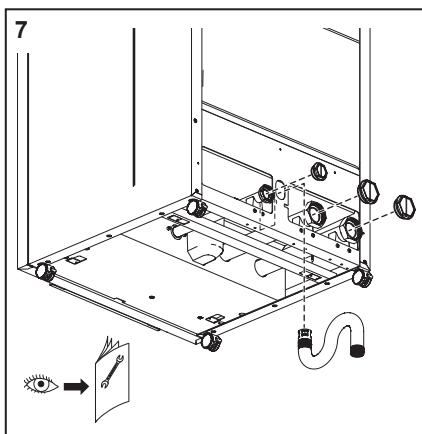
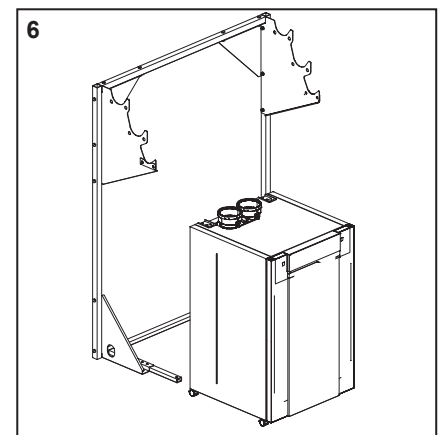
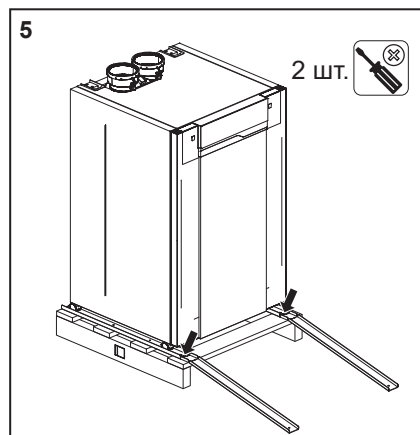
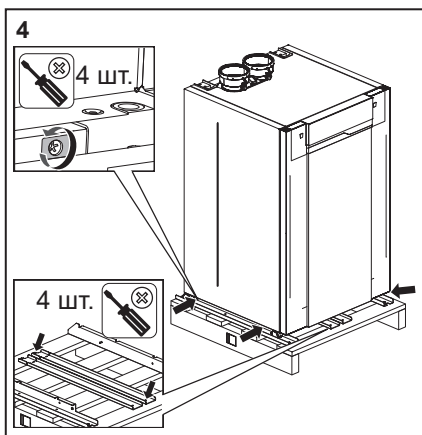
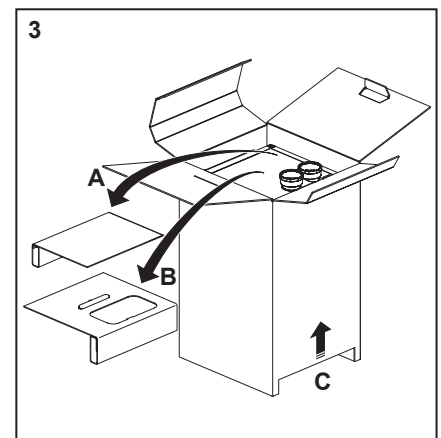
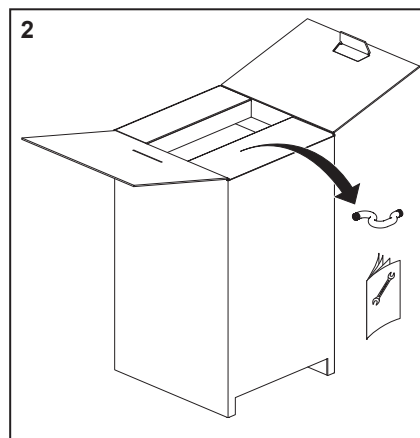
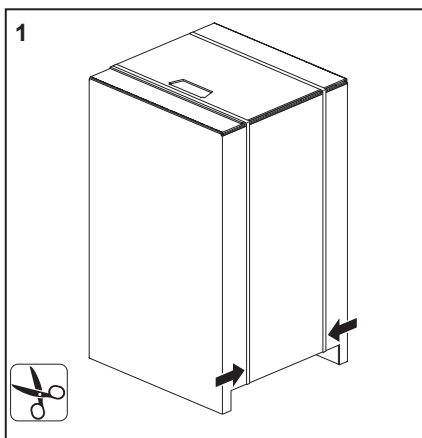

1. Remove the plastic strip.
2. Open the 4 upper folders, and remove the documentation and the condense pipe.
3. Remove the carton inserts, remove the carton box.
4. Remove the 4 screws from the bottom part of the boiler and from the roll off rails on the pallet.
5. Position and fix the roll off rail on the pallet, push the boiler forward along the roll off rail to the ground.
6. Move the boiler to the connection or to the cascade rack.
7. Remove the water and gas plastic cap, connect the condense pipe, and follow the installation manual.
8. When the boiler is connected, push the four brakes to block it.

Installation

Installation Connections

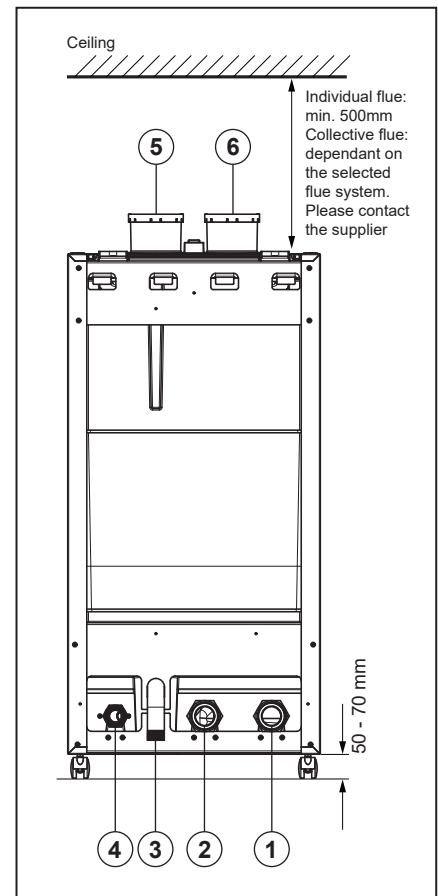
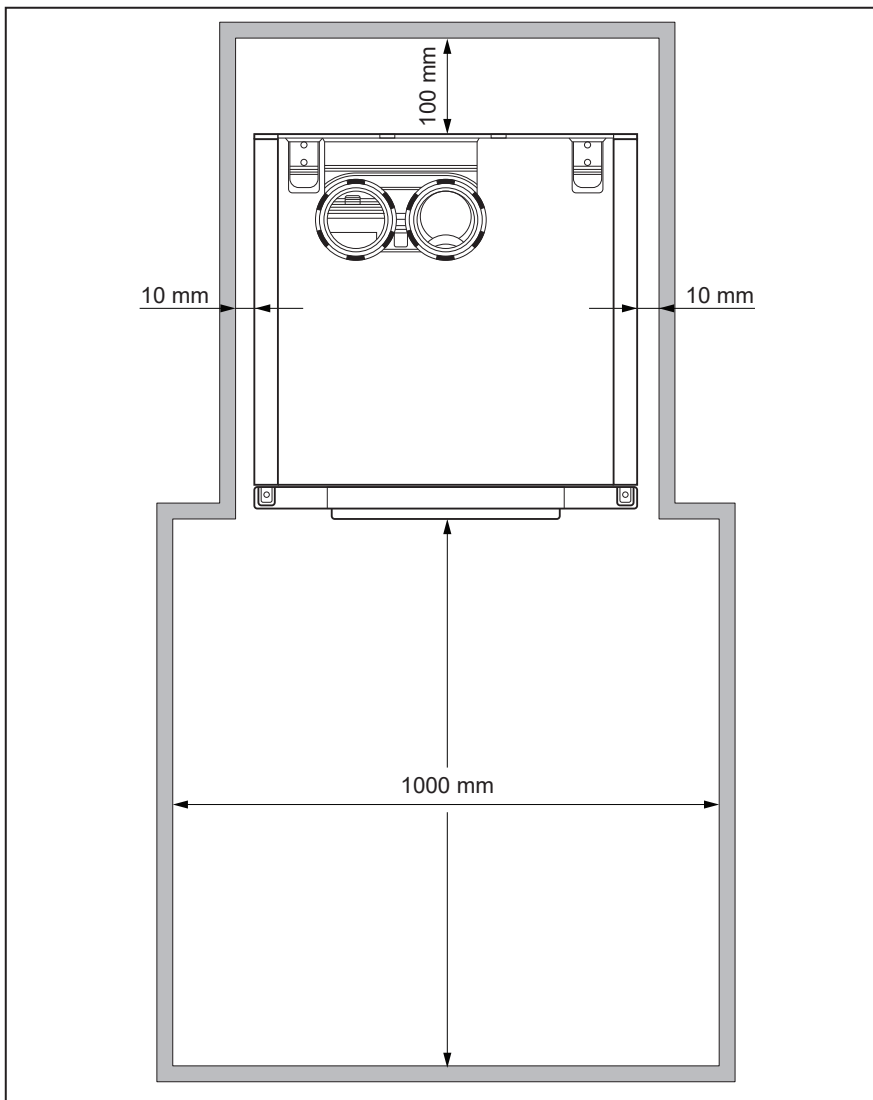

1. Boiler return connection
2. Boiler flow connection
3. Condensate drain
4. Gas
5. Flue gas outlet
6. Air supply

The installation location of the CH-boiler(s) has to be, and remain, frost-free.

It is NOT necessary to have a purpose provided air vent providing a twin pipe or concentric room sealed flue system is used in the room or internal space in which the boiler is installed. Neither is normally required a provision for general cooling due to the very low heat loss from the boiler heat exchanger and casing.

The floor should be flat and level and have sufficient deadweight capacity for the complete (filled) installation. Wheels can be adjusted +/-10mm to compensate eventual floor irregularity.

The Rendamac R1000 cascade can be mounted in 2 ways:

- **Floor standing in line**
All boilers standing alongside one

another in a floor standing frame. Refer to page 21.

- **Floor standing back-to-back.**
All boilers standing back-to-back on a floor standing frame. Refer to page 22.

General guidelines:
Pay attention to the minimum distance required between the boilers, walls and ceiling for installing and removing the housing (refer to above) for commissioning and servicing and installing the flue system (refer to chapter 7).

If you have opted to build the hydraulic part yourself, then Rendamac recommends using "Connection set R1000 as single boiler" for each boiler.



Installation

Hydraulics Circulation pumps

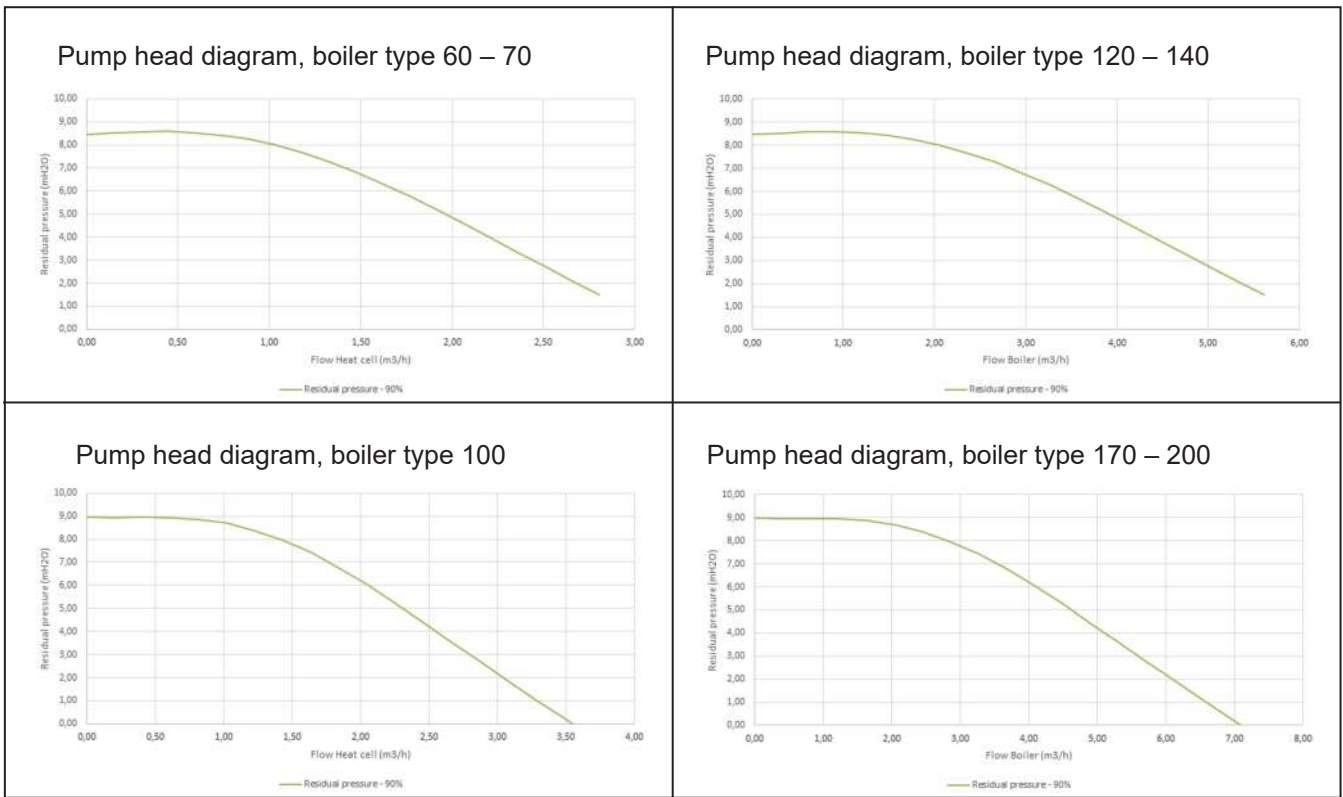

Boiler type	Pump type	Circulating water volume heat cell (m ³ /h - l/min)		Residual head (mH ² O - mbar - kPa)	
		ΔT_{20} (K)	ΔT_{25} (K)	ΔT_{20} (K)	ΔT_{25} (K)
60	1 x WILO PARA 8	2,4 - 40,6	1,9 - 32,5	3,0 - 300 - 30	5,2 - 520 - 52
70	1 x WILO PARA 8	2,8 - 46,7	2,2 - 37,4	1,5 - 150 - 15	4,0 - 400 - 40
100	1 x WILO PARA 9	3,8 - 64,7	3,1 - 51,7	-	2,0 - 200 - 20
120	2 x WILO PARA 8	2x 2,4 - 40,6	2x 1,9 - 32,5	3,3 - 330 - 33	5,4 - 540 - 54
140	2 x WILO PARA 8	2x 2,8 - 46,7	2x 2,2 - 37,4	1,5 - 150 - 15	4,0 - 400 - 40
170	2 x WILO PARA 9	2x 3,8 - 64,7	2x 3,1 - 51,7	-	2,0 - 200 - 20
200	2 x WILO PARA 9	2x 3,8 - 64,7	2x 3,1 - 51,7	-	2,0 - 200 - 20

Installation

Cascade floor standing in line

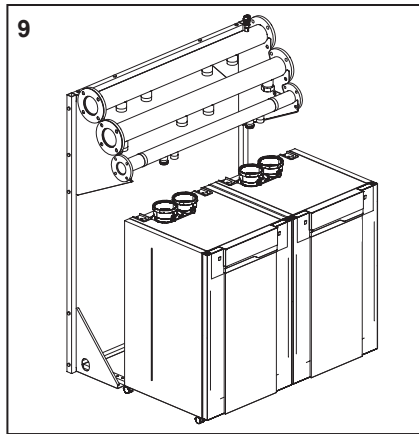
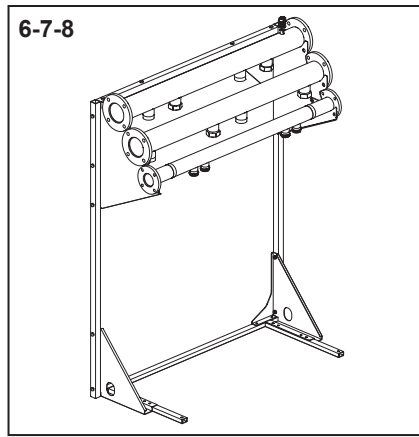
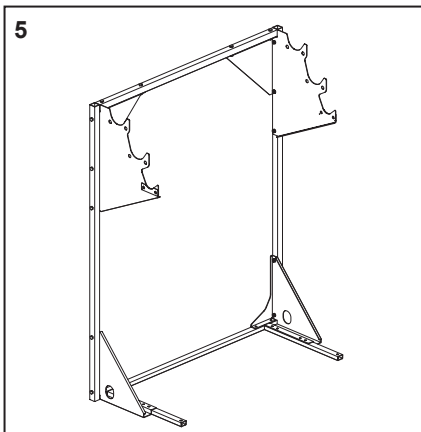
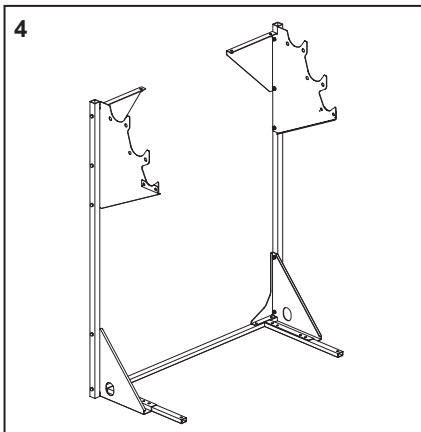
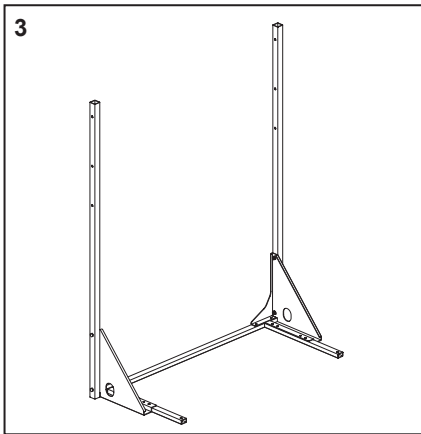
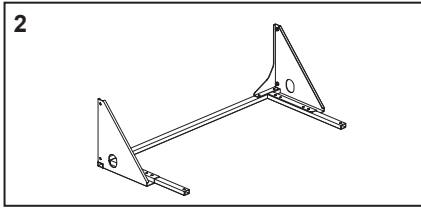
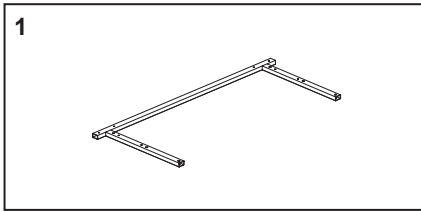

Collector assembly

6. Place the flow water collectors in the upper recess.
7. Place the return water collectors in the middle recess. Couple the water lines using the supplied DN100 gaskets, M16 bolts, spring washers and nuts.
8. Place the gas collectors in the lower recess. Couple the gas lines using the supplied DN65 gaskets, M12 bolts, spring washers and nuts.

Boiler positioning

9. Move the boiler in front of the floor standing rack. Once connected the boiler with dedicated connection kit, push the four brakes to block it.

Floor standing rack assembly

1. Position the lower beam on the ground in the required location.
2. Fit the lower brackets on the lower beam using the supplied M8 bolts, spring washers and nut.
3. Fit the vertical columns on the lower bracket using the supplied M8 bolts, spring washers and nut.
4. Fit the upper brackets on the vertical pale using the supplied M8 bolts, spring washers and nut.
5. Fit the upper beam on the upper brackets using the supplied M8 bolts, spring washers and nut.

Attention: once in the correct and final position, the floor standing rack has to be fixed on the ground.

Additional cascade floor standing

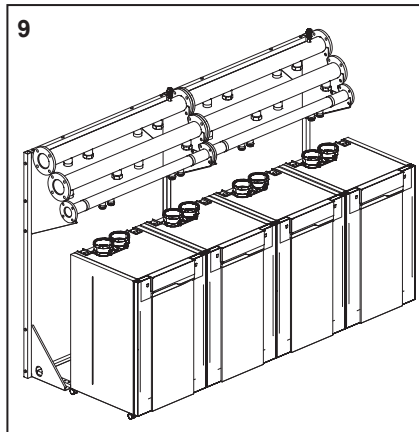
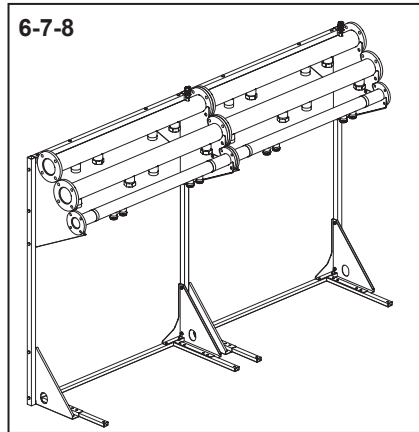
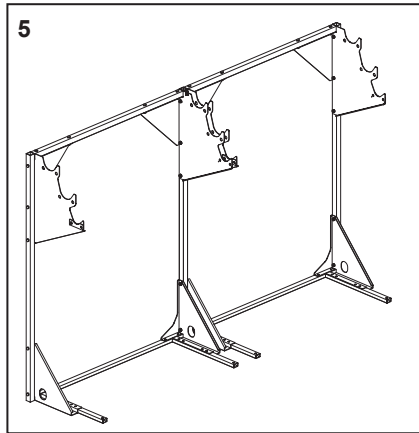
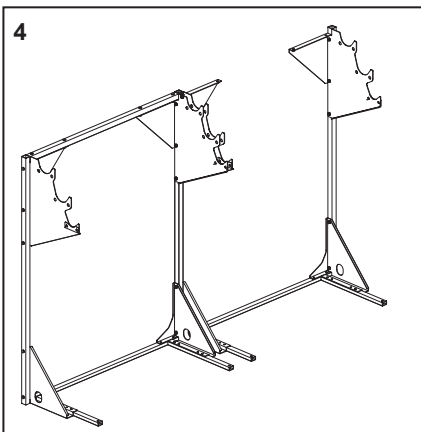
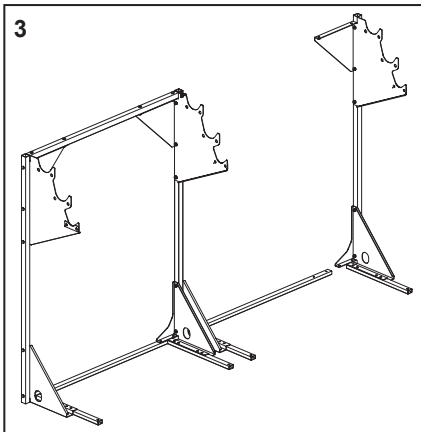
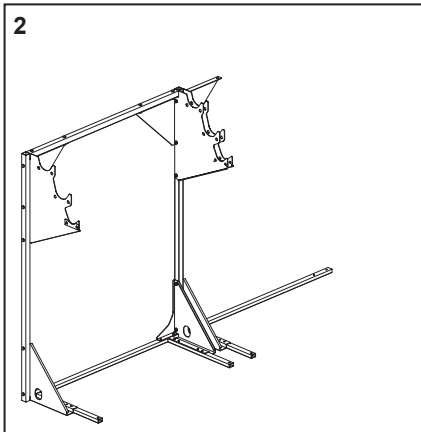
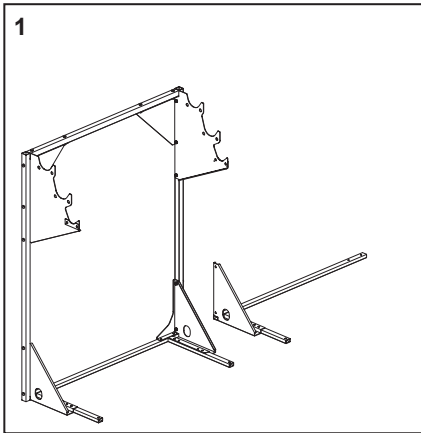

5. Fit the upper beam on the upper brackets using the supplied M8 bolts, spring washers and nut.

Attention: once in the correct and final position, the floor standing rack has to be fixed on the ground.

Collector assembly

6. Place the flow water collectors in the upper recess.
7. Place the return water collectors in the middle recess. Couple the water lines using the supplied DN100 gaskets, M16 bolts, spring washers and nuts.
8. Place the gas collectors in the lower recess. Couple the gas lines using the supplied DN65 gaskets, M12 bolts, spring washers and nuts.

Boiler positioning

9. Move the boiler in front of the floor standing rack. Once connected the boiler with dedicated connection kit, push the four brakes to block it.

Floor standing rack assembly

1. Position the additional lower beam on the ground, next to the existing cascade. Fit the lower brackets on the lower beam using the supplied M8 bolts, spring washers and nut.
2. Fit the additional lower beam and the upper bracket with existing vertical columns using the supplied M8 bolts, spring washers and nut.
3. Preassembly (on the other side) the vertical column with lower and upper beam.
4. Fit the preassembled vertical column with lower beam.

Installation

Connecting the boiler

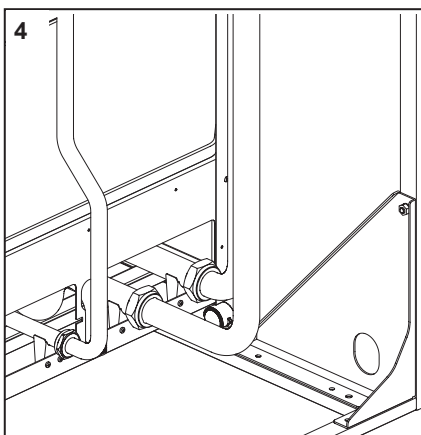
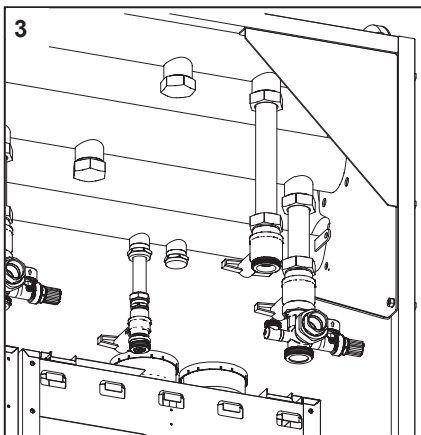
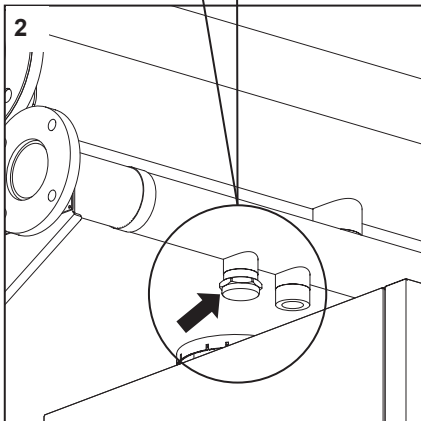
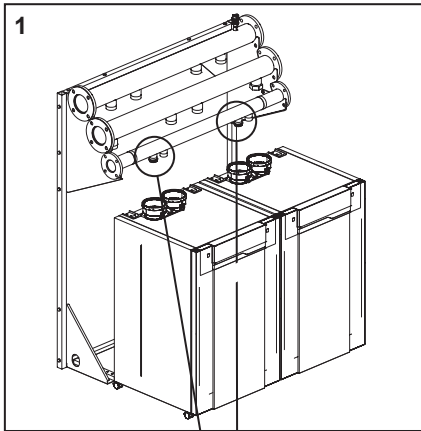

1-2. Keep the cap on the connections that are not used on the pipe work headers:

Flow and return: 2" blind cap with gasket (2 items/boiler).
Gas: 1 1/4" blind cap with gasket (1 item/boiler).

For connections, use the supplied gaskets. Check all connections for leakage and gas-tightness.

3. Connect the valves to the pipe work headers:

Flow: 45mm pipe pieces with 2" flat coupling, 2" flat coupling isolation valve with red handle.
Return: 45mm pipe pieces with 2" flat coupling, 2" flat coupling fitting cross union with fill/drain valve and isolation valve with blue handle.

The boiler is supplied with a 3 and 6 bar safety valve.
Rendamac recommend fitting the 6 bar safety valve due to the control settings shutting the boiler off at 6 bar.

Gas: 28mm short gas pipe with 1 1/4" flat sealing and 28mm compression fitting with 1/4" gas isolation valve.

Polluted test water may be released when removing the plastic caps on the boiler flow and return.

For connections, use the supplied gaskets. Check all connections for leakage and gas-tightness.

4. Connect the pipes to the boiler:
Flow: 45mm pipe pieces with 2" flat coupling.
Return: 45mm pipe pieces with 2" flat coupling.
Gas: 28mm pipe piece with 1/4" flat coupling.

5. Connect the pipes to the valves:
Flow: 45mm pipe pieces with 2" flat coupling.
Return: 45mm pipe pieces with 2" flat coupling.
Gas: 28mm pipe piece with 1/4" flat coupling.

For connections, use the supplied gaskets. Check all connections for leakage and gas-tightness.

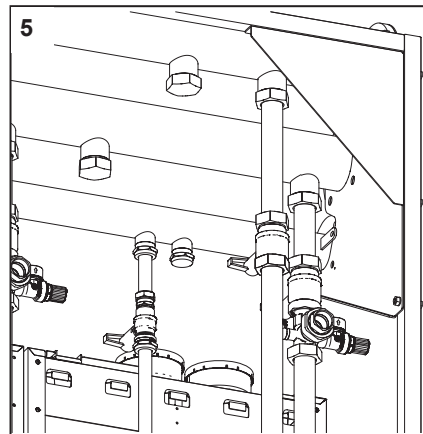

Cascade accessories

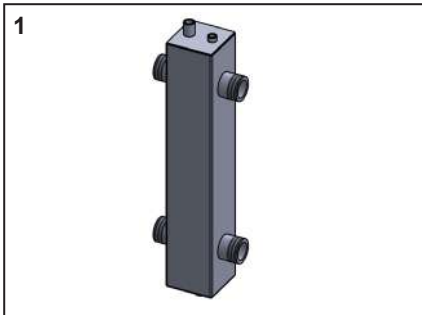

The pipe work headers are available in the dimension DN100 and are connected to one another by the flange couplings and gaskets, M12 or M16x55 bolts, spring washers and nuts. The low loss header and the complete installation can then be connected to it.



1.2.3. Low loss header

There are 3 low loss headers available:

- Low loss header for 1 R1000 to max. 200kW supplied with automatic air vent, drain valve and pocket for temperature sensor T10. Boiler connections are 2x 2", installation connections are 2x 2".

The low loss header **MUST** be connected between the boiler[s] and the system pumps.

- Low loss header DN100 to 1000kW
- Low loss header DN100 DUO to 1600kW.



The low loss header comes standard with adjustable feet, automatic air vent, drain valve, pocket for temperature sensor T10, M12 or M16x55 bolts, spring washers and nuts.



4. Pipe work header connection pipe

Connection pipes for pipe work headers are available in the dimension DN100 in two versions, for a connection on the LEFT or on the RIGHT side of the cascade. They come standard with M16x55 bolts, spring washers, nuts and sealings.



5. Flow temperature sensor T10

Every system with 1 or more R1000-boilers must be provided with a flow temperature sensor T10 and must be connected on the master boiler (MTS1-T10). The flow sensor must be placed in the pocket of the low loss header.



6. Set of bends

The low loss header can be positioned at a 90° angle. A set of bends may be used for that purpose.

- Bends set DN100 flow/return



7. Blanking flanges

The ends of the pipe work headers have to be fitted with blanking flanges. The blanking flanges come standard with a fully configured delivery, including bolts, spring washers and gaskets.

- Blanking flange set DN100 flow/return 2 items



8. Welded-on flanges

Upon request, welded-on flanges are available to connect CH-pipe lines to the secondary side of the low loss header and to connect the gas line.

- Welded-on flange set DN100 flow/return 2 items + DN65 gas 1 item

For complete overview on available accessories please refer to paragraph "R1000 Cascade accessories".

Required components that are not supplied by Rendamac:

- The installation pump;
- The condensate discharge system
- The installation water filter;
- Air and dirt separator;
- Hot water supply;
- Regulation valve;
- Expansion vessel(s).

Installation

Accessories Single boiler external

1x R1000 boiler

Necessary articles
1. Low loss header for 1 boiler
Low loss header (included)
fixation bracket (included)
air vent (included)
1. Low loss header insulation
1. Boiler connection set for single boiler
1. Common flow sensor 10kOhm T10

Accessories Single boiler back-pack

Connection description

- A - flow
- B - return
- C - gas
- D - condense

Single boiler back-pack

This accessory is a back-pack plug and play solution with R1000 boiler.
It's available in the version:

- Low loss header dT10-20k (for 70-100 kW)
- Low loss header dT10-20k (for 120-200 kW)
- Plate HEAT EXCH. dT10k (for 70-100 kW)
- Plate HEAT EXCH. dT10k (for 120-200 kW)
- Plate HEAT EXCH. dT15k (for 70-100 kW)
- Plate HEAT EXCH. dT15k (for 120-200 kW)
- Plate HEAT EXCH. dT20k (for 70-100 kW)
- Plate HEAT EXCH. dT20k (for 120-200 kW)

Installation

Cascade accessories

Dimensions headers, low loss headers and bends

Dimensions low loss header DN100 until 1000kW

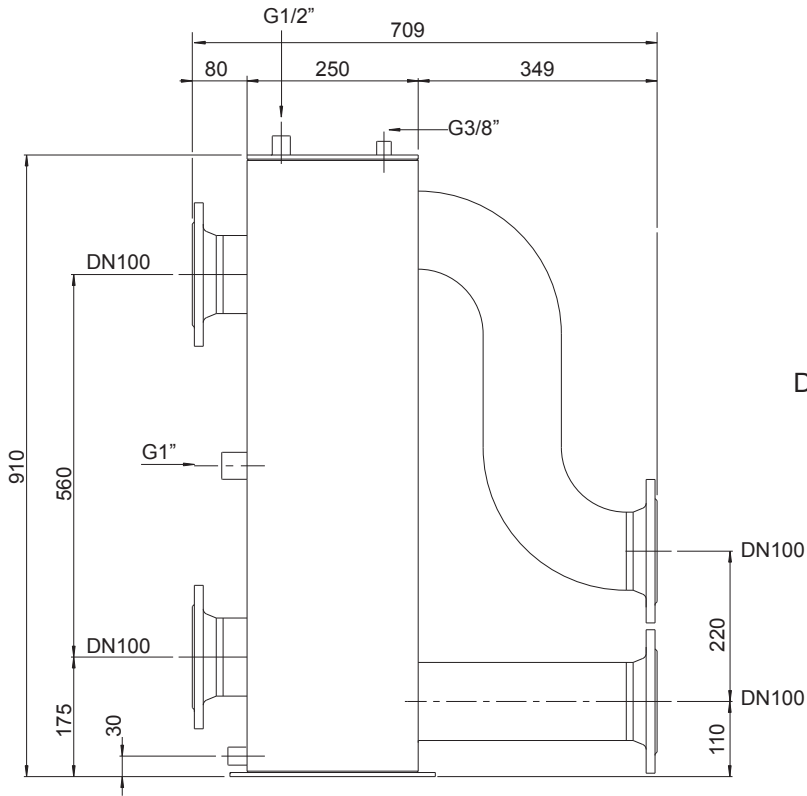

Dimensions pipe headers DN100

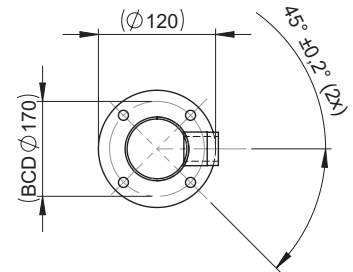

Dimensions bend DN100

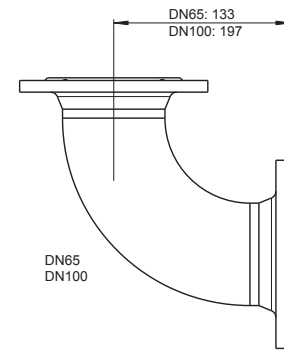

Dimensions low loss header DN100 until 1600kW

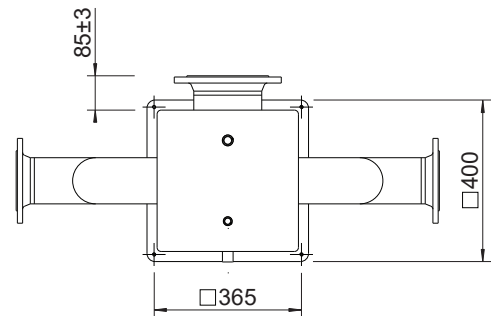
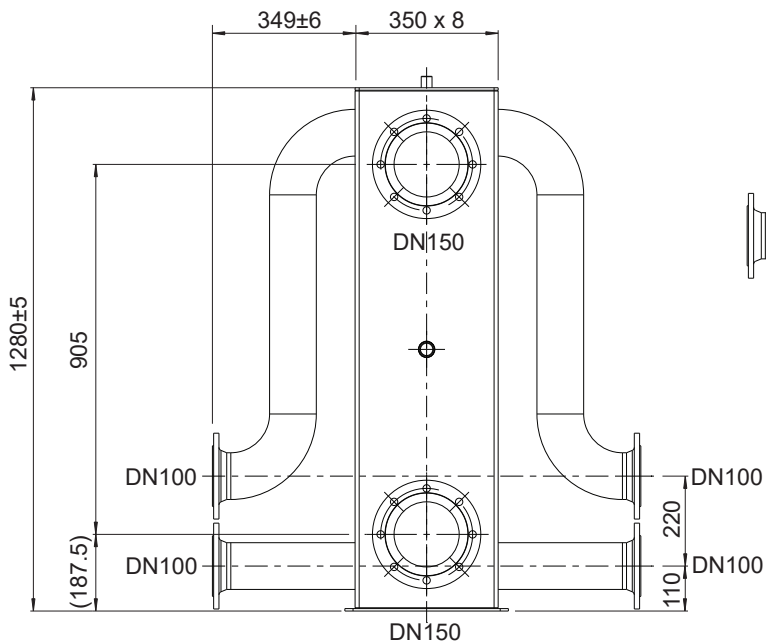

Installation

Water and hydraulic system Heating water quality

Fill the installation with drinking water.

In most cases, a central heating installation can be filled with water according to the nationally valid regulations, whereby a treatment of the water is not necessary.

To avoid problems, the quality of the filling water must conform to the requirements in Table 1.

If the filling water should not conform to these requirements, then it is recommended to treat the water correspondingly (see VDI2035).

Warranty claims become invalid if the system has not been flushed during installation, or if the filling water quality does not conform to the Rendamac requirements (see Table 1).

If anything should not be clear, or in case of deviations, always take up contact with Rendamac first. The warranties lapse, if any changes are made without an advance agreement/release by Rendamac.

Installation:

- The use of groundwater and distilled water, is not permitted (an explanation of these terms can be found on the next page).
- If the drinking water quality lies

within the limits of the values in Table 1, then one can proceed with the installation of the system and the flushing of the equipment.

- Residues of corrosion products (magnetite), assembly materials, cutting oil and other undesirable products, must be removed during the flushing operation.
- Another possibility for removing dirt is the use of a filter. The filter type must conform to the system-specific requirements and the type of contamination. Rendamac recommends the use of a filter. In such a case, one should make sure to take the entire piping system into consideration.
- The central heating installation must be de-aerated properly, before it is taken into operation. Please review the Chapter "Commissioning" in this regard.
- If a regular topping up of water is required (> 5% per year), then there is a problem with the system that must be rectified by a certified technician. Regular topping up with fresh water and oxygen adds lime to the system, which leads to deposits.
- If an anti-frost agent or other

additives are used, then it must be regularly checked to ensure that the filling water quality conforms to the manufacturer requirements.

- Inhibitors may only be used after consultation with Rendamac.
- The use of such agents must be protocolled.

Floor heating

When a floor heating system is connected that uses plastic pipes, it must be ensured that it conforms to the standard DIN 4726-4729. If the system does not fulfil the standard, then a system separation must be foreseen.

If the regulations with regard to plastic piping are not observed, then warranty claims become null and void (see the warranty conditions).

Parameters	Value
Water type	Drinking water Softened water
pH	6.0-8.5
Conductivity (at 20°C in µS/cm)	Max. 2500
Iron (ppm)	Max. 0.2
Hardness (°dH / °fH)	
Installation volume/performance <20 l/kW	1-12 °dH / 1-21.5 °fH
Installation volume/performance ≥20 l/kW	1-7 °dH / 1-12.5 °fH
Oxygen	Oxygen diffusion is not permitted during operations. Max. 5% of the system volumes may be topped up annually.
Corrosion inhibitors	See the Chapter "System water additives (inhibitors)"
pH raising or lowering agents	See the Chapter "System water additives"
Anti-frost additives	See the Chapter "System water additives"
Other chemical additives	See the Chapter "System water additives"
Solid substances	Not permitted
Residues in the heating water, which are not a component of the drinking water are	Not permitted

Table 1

Installation

System water additives

The system water additives, which are listed in the table, have been released by the manufacturer and take into consideration the indicated dosage quantities.

In case of a wrong use, and if the maximum concentration quantities are exceeded, then the guarantee for all components that come in contact with heating water are null and void.

Additive type	Supplier and specifications	Max. concentration	Application
Corrosion inhibitors	Sentinel X100 Corrosion resistant protection agent of CH systems Kiwa certified	1-2 l/100 litres CH water content	Aqueous solution of organic and inorganic agents preventing corrosion and scale forming
	Fernox F1 Protector Corrosion resistant protection agent of CH systems Kiwa certified KIWA-ATA K62581, Belgaqua certified Cat III	500 ml can or 265 ml Express / 100 litres CH water content	Preventing corrosion and scale forming
Anti-freeze	Kalsbeek Monopropyleneglycol / propane-1,2-diol + inhibitors AKWA-Colpro KIWA-ATA Nr. 2104/1	50% w/w	Anti-freeze
	Tyfozor L Monopropyleneglycol / propane-1,2-diol + inhibitors	50% w/w	Anti-freeze
	Sentinel X500 Monopropyleneglycol + inhibitors Kiwa certified	20-50% w/w	Anti-freeze
	Fernox Alphi 11 Monopropyleneglycol + inhibitors Kiwa certified KIWA-ATA K62581, Belgaqua certified Cat III	25-50% w/w	Anti-freeze in combination with F1 Protector
System cleaners	Sentinel X300 Solution of phosphate, organic heterocyclic compounds, polymers and organic bases Kiwa certified	1 litre / 100 litres	For new CH installations Removes oils/grease and flow control agents
	Sentinel X400 Solution of synthetic organic polymers	1-2 litres / 100 litres	For cleaning existing CH-installations Removes sediments.
	Sentinel X800 Jetflo Aqueous emulsion of dispersants, moistening agents and inhibitors	1-2 litres / 100 litres	For cleaning new and existing CH-installations Removes iron and lime-related sediments.
	Fernox F3 Cleaner Liquid pH neutral universal cleaner for pre-commissioning new systems	500 ml / 100 litres	For cleaning new and existing CH-installations Removes sludge, limescale and other debris.
	Fernox F5 Cleaner, Express pH neutral universal cleaner concentrate for pre-commissioning new systems	295 / 100 litres	For cleaning new and existing CH-installations Removes sludge, limescale and other debris.

Installation

Expansion vessel

Expansion vessel

The CH-installation has to be fitted with an expansion vessel. The expansion vessel used has to comply with the water contents of the installation.

It is not necessary to install an expansion vessel to each boiler. One single, central installed expansion vessel is sufficient. When using a single expansion vessel the handles of the valves on the flow and return pipes below the boiler have to be removed whilst open.

A boiler expansion vessel can be connected on the cross union inside the return pipe to each boiler, if required. The connection is fitted with a 3/4" outer thread blanking cap.

Expansion DHW cylinder circuit

When applying a DHW cylinder connected directly to the boiler (Rendamax cylinder connection with use of 3-way valve) the circuit between the three-way valve and the separation of the DHW cylinder should be provided of an expansion tank. See also page 34.

For installation in UK, please refer to UK standards.

Installation

Gas line

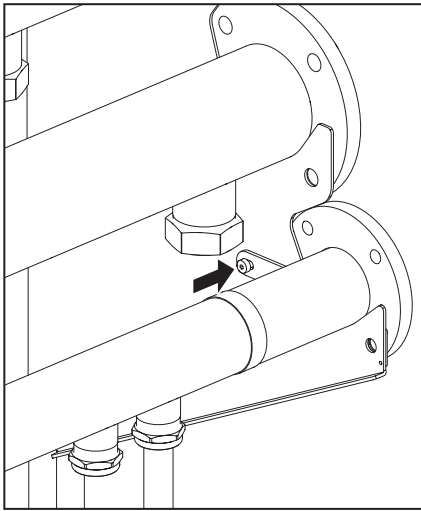

The gas line leading to the installation has to be calculated to the maximum capacity to determine the diameter of the supply pipe.

The gas line has to be placed on the allocated openings of the upper bracket of the cascade rack and secured on all flange plates by the special M6x8x16 close tolerance bolts.

Pressure loss for a newly installed natural gas line may be 1.7 mbar max. In the case of an extension, this may be 2.5 mbar max. This value is to be measured in between the operational gas meter and the CH-boilers.

For correct functioning of the boilers, it is necessary that the gas dynamic inlet pressure must be at least 19 mbars. This value is to be measured in front of the gas flange connection.

With regard to new lines in particular, ensure that the gas line does not contain any residual pollution.

ATTENTION:

For use with propane gas, the LPG conversion kit has to be installed, see separate conversion instructions. Following maintenance tasks always check all gas carrying components for leakages by using of leakage detection fluid (LDF).

Installation

Condensate connection



HAZARD:

Danger of death due to poisoning! If the siphon is not filled with water, or if any connections are open, then escaping waste gas can pose a hazard of death for people.

Condensate connection

For every m³ of natural gas that is burned, between 0.7 and 1.0 litres of water can accumulate, due to a very high energy utilization. Condensate, which accumulates in the boiler, in the waste gas pipe or in the chimney, must be drained to the public sewage system.

In this regard, country-specific regulations must be taken into account. A neutralization of the condensate may be required. It must be possible for the condensate to visibly drain into a funnel-siphon (2) at the installation site. A fixed connection to the public sewer system is not permitted.

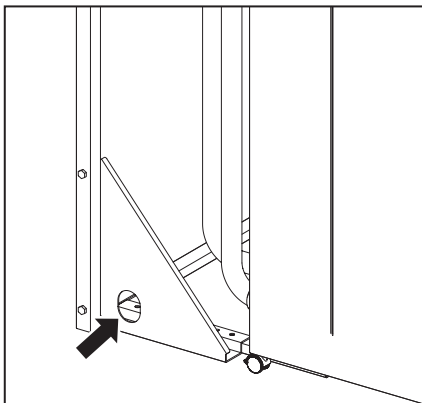
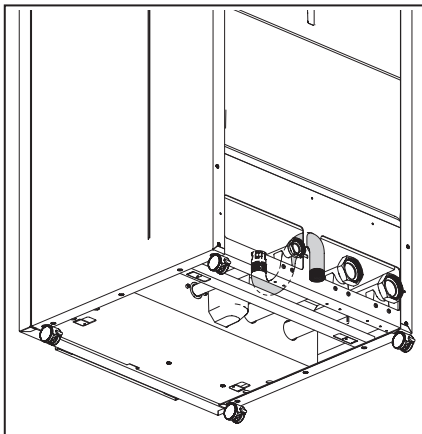

For condensate drainage, only corrosion-resistant and certified materials may be used. The drainage must be carried out in a frost-free space. The drainage pipe should have a slope, so as to avoid a backwash of the condensate.

Filling of the siphon

Before the boiler is taken into operation, the equipment siphon (1) must be filled with water, so as to prevent an emission of waste gas from the condensate connection. Filling is carried out most easily by pouring approximately 0.5 litres of water into the waste gas pipe (3).

Once each year the waste gas connections have to be checked for leakproofness and the siphon filled with water.

All PLUS floor standing gas fired condensing boilers contain a siphonic condensate trap to collect and release condensate.

The amount of condensate formed is determined by the type of boilers and the water temperature produced by the boiler.

Condensate pipework.

Press the supplied plastic ribbon tube onto the condensate drain at the bottom of the boiler. Connect the tube to the main condensate drain (minimum diameter= 40mm) by means of an open connection to avoid sewage gasses coming into the boiler.

Fit a pipe work header for the condensate drain behind the hydraulic system. For that purpose, the lower brackets have holes allowing the installation of a PVC drain of $\varnothing 40\text{mm}$ max. Use this drain to connect the individual condensate drains of each boiler.

The siphon of a flue gas system can also be connected, if required, by means of an open connection.

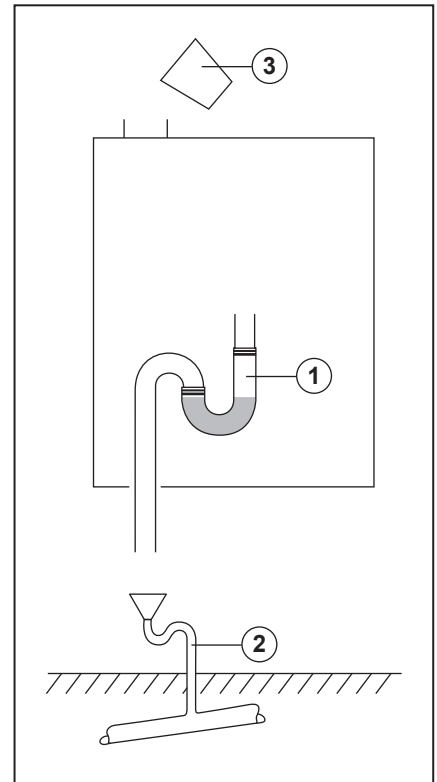

Installation

Hot water supply

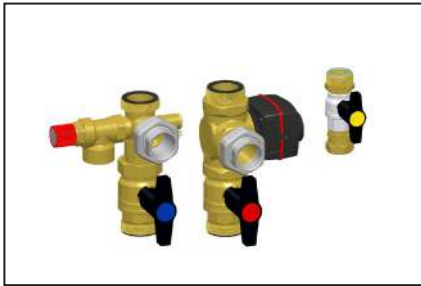

The hot water supply control can be connected to the Rendamac R1000. For connection and settings refer to the Boiler Control chapter.

Expansion DHW cylinder circuit

When connecting a DHW cylinder to the boiler before the low velocity header an Rendamax diverter valve is recommended.

The circuit between the diverter valve [1] between the boiler and cylinder should be provided with an expansion vessel [2].

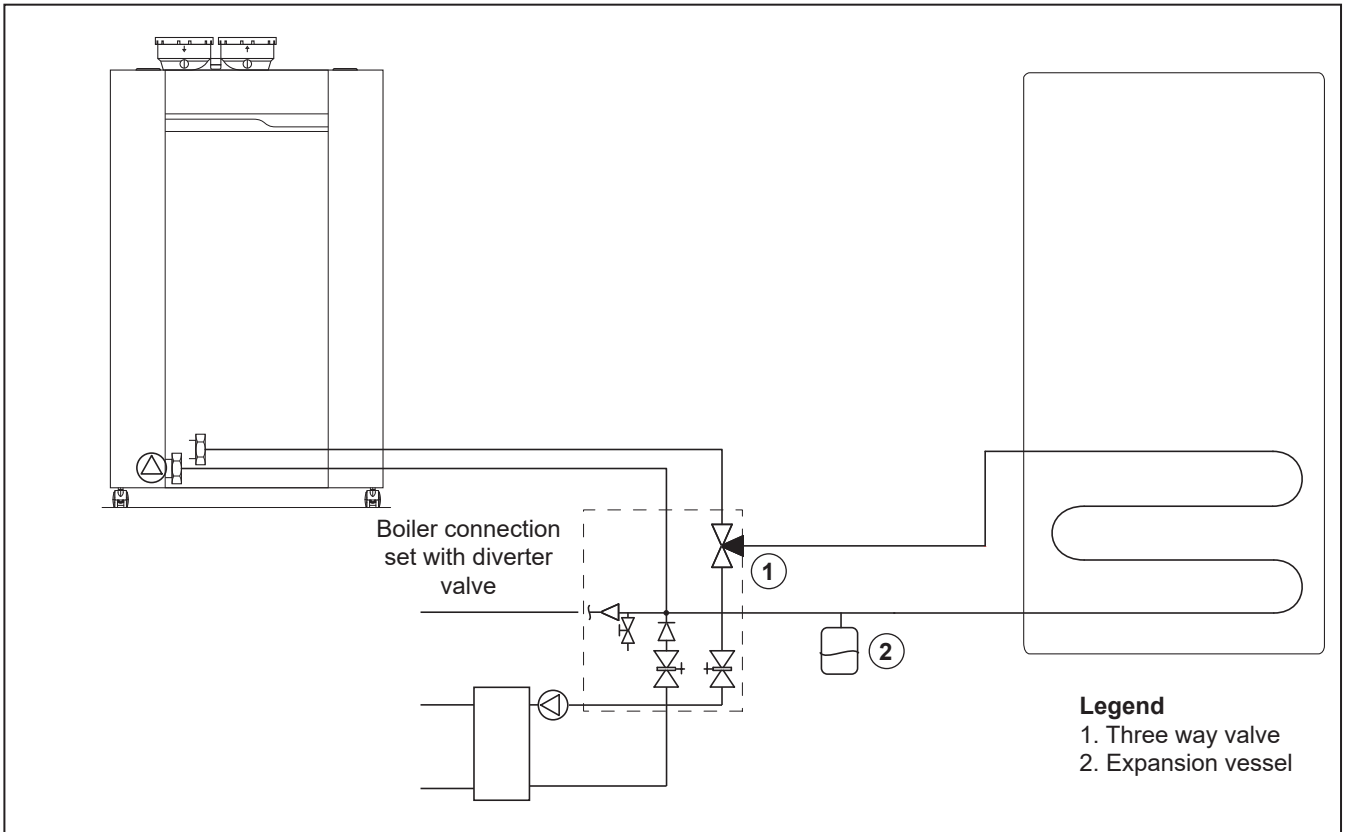

Installation

Connections

Air- / flue gas ducts for individual boilers

All boiler models have a parallel flue connection.

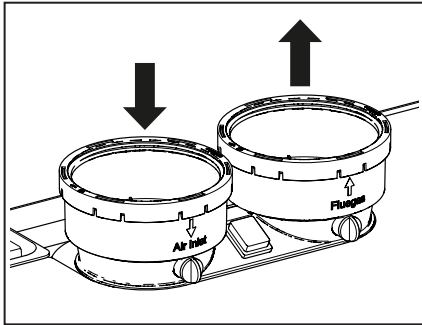

Flue gas connection

We recommend the use of Rendamac's comprehensive range of flue gas components.

For further information, please see the installation instructions:

- Rendamac wall terminals
- Rendamac roof terminals
- Rendamac flue pipe components, both individual pipes and concentric tubes.

Regulations about the construction and installation of flue gas systems are different from country to country. It must be ensured that all national regulations with regard to chimney systems are observed.

It is not necessary to install a separate condensate drain for the flue gas system, since the condensate will be flushed out via the boiler and into the siphon. Please observe the following recommendations:

- Only use corrosion-resistant material
- The diameter must be calculated and selected according to the national regulations.
- The length of the flue gas system must be kept as short as possible (and must not exceed the maximum permitted length, see the documentation for planners)
- Horizontal flue gas tubes must have an inclination of at least 3° back towards the boiler.

Air supply connection

If required, a separate room sealed air supply tube may be connected via the inclusion of the optional air supply connector fitting. The diameter must be calculated in conformity with national regulations and in combination with the flue gas system. The overall resistance of the air supply and flue gas tubes may not exceed the maximum supply pressure of the Fan at any time. (Also see the Chapter "Technical data")

Notes

The tables below give guidance on the maximum lengths of air and flue gas tubes that may be connected. If a room sealed installation is being made utilising separate air and flue gas tubes, the lengths of both tubes must be added together and not exceed the relevant value given in the tables.

The radius of any bend used in the flue gas system must not exceed 87.5°.

Walls that are sensitive to heat should be insulated.

Construct the flue system in such way that no recirculation may take place.

Dimensioning (reference value)

Changes of direction	Ø tubes (open or parallel tubes room sealed installation)	Maximum length in metres			
		0	2	3	4
60	Ø100 mm	82	78	76	74
70		60	56	54	52
100		34	30	28	26
120		20	16	14	12
140		16	12	10	8
170	Ø130 mm	35	30	27	25
200		30	25	22	20

Changes of direction	Ø tubes (concentric room sealed installations)	Maximum length in metres			
		0	2	3	4
60	Ø100/150 mm	23	19	9	8
70		13	9	9	8
100		10	6	7	6
120		8	5	3	2
140		9	6	5	3

Required minimum (flue enclosure) shaft cross-section		
Diameter flue duct	Square shafts	Round shafts
100 mm	140 x 140 mm	160 mm

Installation

Connections

Air- / flue gas ducts for individual boilers

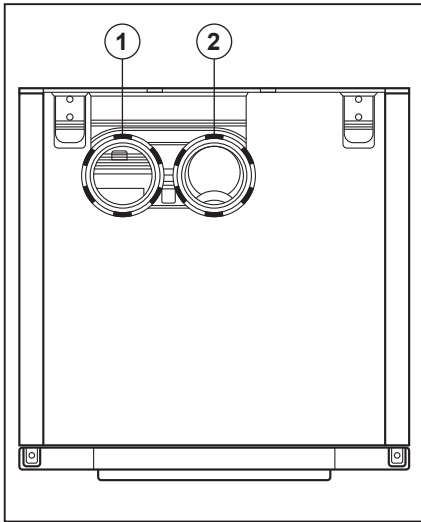

Boiler type	Air duct - flue gas diameter
60	100 - 100
70	100 - 100
100	100 - 100
120	100 - 100
140	100 - 100
170	130 - 130
200	130 - 130

Parallel boiler connection

The boiler comes as standard with a parallel connection for the flue gas outlet and air supply system. For the air supply opening (1) diameter and the flue gas outlet connection (2), see table below. The air supply channel can be connected to it, or, if it involves an "open device" (Drainage category B), an air filter is recommended.

Concentric boiler connection

The boilers 60-70-100-120-140 can be converted into a concentric connection using the parallel/concentric adapter 100/150 (optional) and carrying out the following tasks:

- Open and remove the frontal panel and the top panel (follow the instruction on page 42).
- Lift the parallel connection.
- Disconnect the main switch 230V connection and remove it.
- Replace the parallel connection with parallel concentric adapter.
- Connect and fit the main switch 230V according to previous configuration.

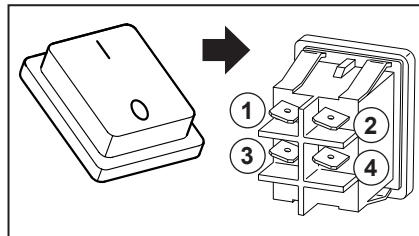

The air supply opening has a diameter of $\varnothing 150\text{mm}$.

The flue gas outlet connection has a diameter of $\varnothing 100\text{mm}$.

The flue gas outlet-/air supply system is then connected to the concentric connection component.

The R1000-boilers can be used both in an "open" and in "closed" system.

Open system

The required combustion air is taken from the immediate environment (boiler room). For this purpose, please comply with the applicable boiler room ventilation regulations.

When using boiler category B23 and B33 as an 'open boiler', the protection degree of the boiler will be IPX0D instead of IPX4D.

An air filter or a grid is recommended on the air intake of the boiler (available as an accessory on pages 15-17).

Closed system

The required combustion air is sucked in from the outside through a channel. This improves installation possibilities within a building. In general, outside air is cleaner than air from the boiler room.

When the boiler is operational, it produces a white plume of condensation. This condensation plume is harmless but may cause some inconvenience, particularly in the case of wall terminal. As a result, roof terminals are preferred.

In a closed installation, roof terminals should be at the same height preventing flue gas from being sucked in by the other boiler (recirculation). Outlets in recesses and near erected walls may also bring about flue gas recirculation. Recirculation has to be prevented at all times.

For installation in UK please refer to installation guidance in BS6644 and IGE UP10.

Fan settings correction

By setting parameter (21-2-4) it is possible to compensate for a higher flue gas pressure difference. It is required to have a pressure drop calculation of the applied flue gas system.

According to the calculated pressure drop, the correct value for parameter (21-2-4) has to be chosen from the table below.

For setting parameters see the applicable chapter.

		Flue Gas System pressure drop						
		Boiler type						
Parameter (21-2-4)		R1060	R1070	R1100	R1120	R1140	R1170	R1200
	0 - 600	161	156	243	143	200	215	265
	700	189	204	295	177	230	280	321
	800	226	224	350	207	275	313	370
	900	250	250	405	240	300	375	-
	1000	278	278	457	260	304	375	-

Installation

Connections

Air- / flue gas ducts - installation variants for individual boilers

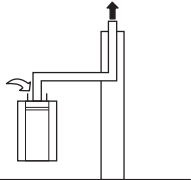
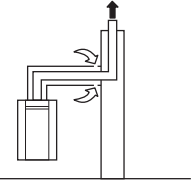
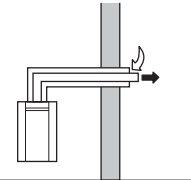
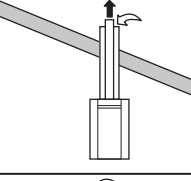
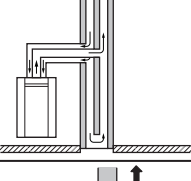
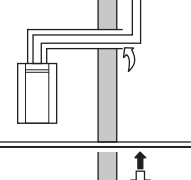
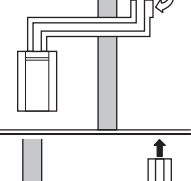
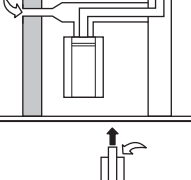
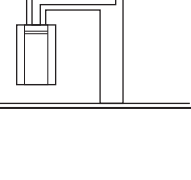
Ambient combustion air		
B23 B23P	Flue gas duct into the chimney, aspiration of air from the surroundings. End section of the waste gas duct above the roof.	
B33	Flue gas duct into the chimney, aspiration of air from the surroundings. End section of the waste gas duct above the roof.	
Combustion air taken from the surroundings		
C13	Flue gas duct and suction air over the outer wall, must be in the same square area.	
C33	The flue gas and suction air ducts via the roof terminal, must be in the same square area.	
C43	Suction air and waste gas duct via the chimney system, which is integrated in the building.	
C53	Section the air and waste gas exhaust to the outside, in areas with different pressures. Vertical end section of the waste gas duct.	
C63	Specially developed equipment, for connection to certified air-/waste gas systems that operate separately from one another.	
C83	Air suction on the outside of the building, waste gas duct via the chimney.	
C93	Air and waste gas piping to the waste gas chimney, via installation in the roof and in a humidity-resistant waste gas chimney.	

Installation

Connections

Air- / flue gas ducts - installation variants for multiple boilers

Opting for a collective flue gas outlet is determined by:

- The position of the boilers with regard to their outlet area
- Sufficient space above the boilers
- Large number of boilers

You may opt for:

- Collective flue gas outlet under-pressure
- Collective flue gas outlet over-pressure

In many situations, flue gases cannot be vented individually because the

installation is indoors. For such situations, we recommend collective venting by means of under-pressure or over-pressure using a flue gas outlet system. The air supply may also be supplied collectively, but if the boiler room is suitable for that purpose it may also be obtained from this area ('open device' Boiler category B).

If you install a common duct providing combustion air to more than one appliance, there is a risk that combustion air would be drawn from an adjacent appliance.

This may then be subject to a negative pressure.

In the case of collective venting of flue gases, the flue gas-venting outlet always has to end up in the open area (outlet area 1).

Rendamac can supply a collective flue gas outlet system for the Rendamac R1000. Refer to the following chapters with regard to the various possibilities and maximum pipe lengths that can be used.

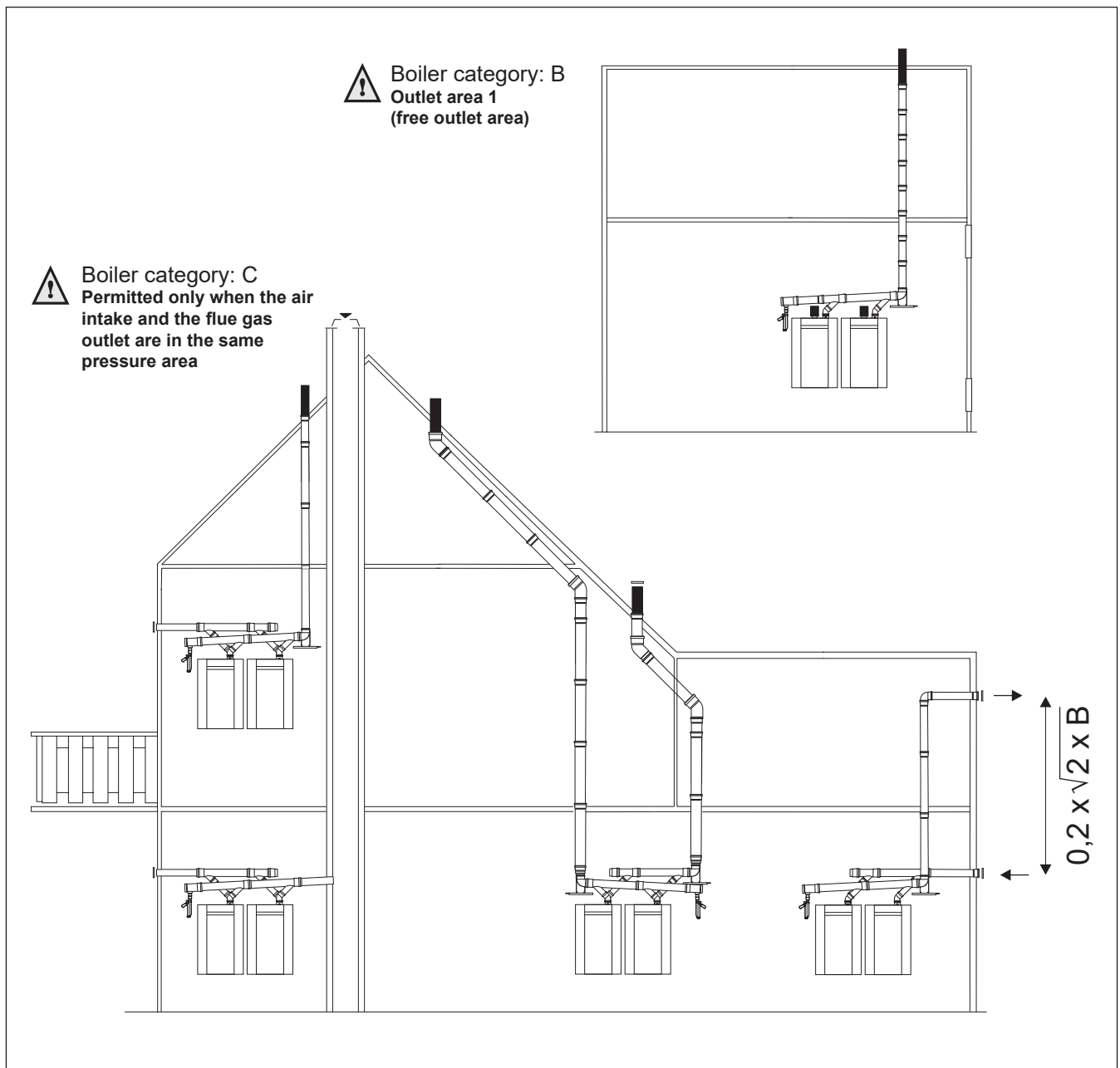

Installation

Connections

Collective flue gas outlet under-pressure

Diameter and venting lengths of the flue gas outlet/air supply:

- Open system, with under-pressure (calculated with thermal draft) under atmospheric circumstances.

NOTE!

1. IPX0D at flue category B₂₃ and B₃₃

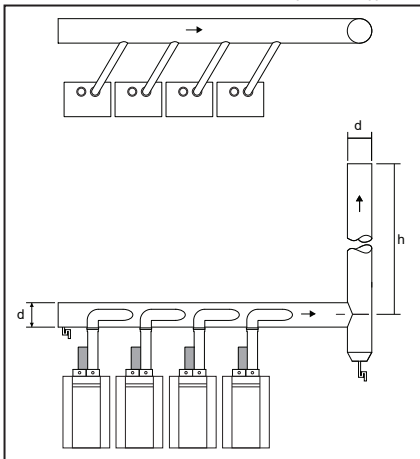

Dimensions cascade flue R0000 Series						
Open system, underpressure						
Output (80/60)			d = minimum diameter Ø in mm			
[kW]			h = 2 - 5	h = 5 - 9	h = 9 - 13	h = 13 - 17
114	-	240	210	200	190	190
240	-	360	300	270	260	250
360	-	480	360	330	310	300
480	-	600	440	380	360	340
600	-	720	470	420	400	380
720	-	840	550	470	430	410
840	-	960	600	510	470	440

Diameter and venting lengths of the flue gas outlet/air supply:

- Closed system, with under-pressure (calculated with thermal draft) under atmospheric circumstances.

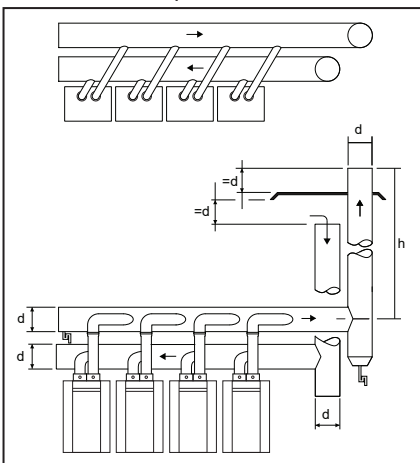

Dimensions cascade flue R0000 Series						
Closed system, underpressure, parallel						
Output (80/60)			d = minimum diameter Ø in mm			
[kW]			h = 2 - 5	h = 5 - 9	h = 9 - 13	h = 13 - 17
114	-	240	240	220	220	220
240	-	360	330	300	290	270
360	-	480	390	370	350	330
480	-	600	460	410	390	380
600	-	720	500	460	440	420
720	-	840	550	500	470	460
840	-	960	600	540	510	490

Installation

Connections Collective flue gas outlet over-pressure

Diameter and venting lengths of the flue gas outlet/air supply:
- Open system with over-pressure.

NOTE!

1. IPX0D at flue category B₂₃ and B₃₃

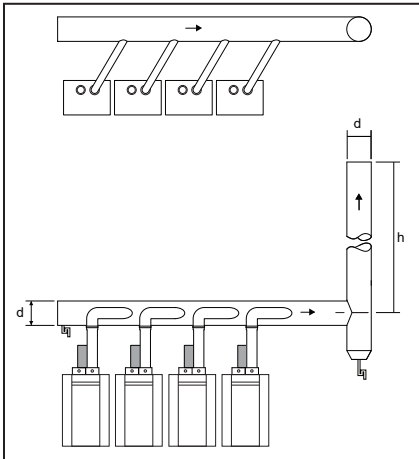

Dimensions cascade flue R0000 Series						
Open system, overpressure						
Output (80/60)			d = minimum diameter Ø in mm			
[kW]			h = 2 - 5	h = 6 - 10	h = 11 - 15	h = 16 - 20
114	-	240	150	150	150	150
240	-	360	150	150	180	180
360	-	480	180	180	180	200
480	-	600	200	220	220	220
600	-	660	230	230	250	250
660	-	872	260	260	260	260
872	-	960	280	280	280	300
960	-	1200	280	280	280	300

Diameter and venting lengths of the flue gas outlet/air supply:
- Closed system with over-pressure.

Please contact Rendamax.

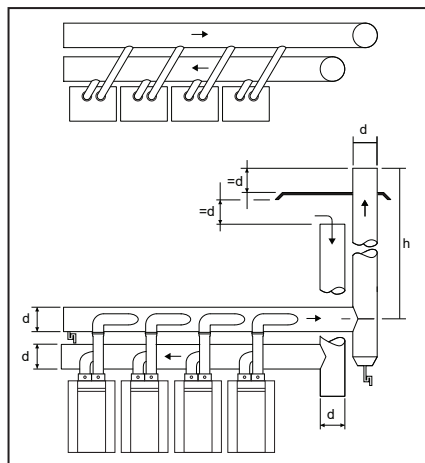

Dimensions cascade flue R0000 Series						
Closed system, overpressure, parallel						
Output (80/60)			d = minimum diameter Ø in mm			
[kW]			h = 2 - 5	h = 6 - 10	h = 11 - 15	h = 16 - 20
114	-	285	150	150	150	150
285	-	524	200	200	200	200
524	-	1440	300	300	300	300

Installation

Electrical connection

Electrical connections must be carried out by an authorized electrical technician, and in conformity with valid national and local standards and regulations. An insulated mains switch must be used for the power supply, with at least 3 mm contact openings. It must be mounted inside of the boiler room. The mains switch is used for switching off the power supply during maintenance works.

All cables are passed through the cable guide at the top of the boiler, and are led to the electronics panel at the front of the boiler.

The electric diagram must be observed during all electrical connection works (see the following pages).

A 230V -50Hz mains electrical supply is required fused externally at 16A.

A deviation on the grid of 230V (+10% or -15%) and 50Hz

The following additional regulations also apply:

- The boiler's wiring is not allowed to be changed;
- All connections have to be made to the terminal block.

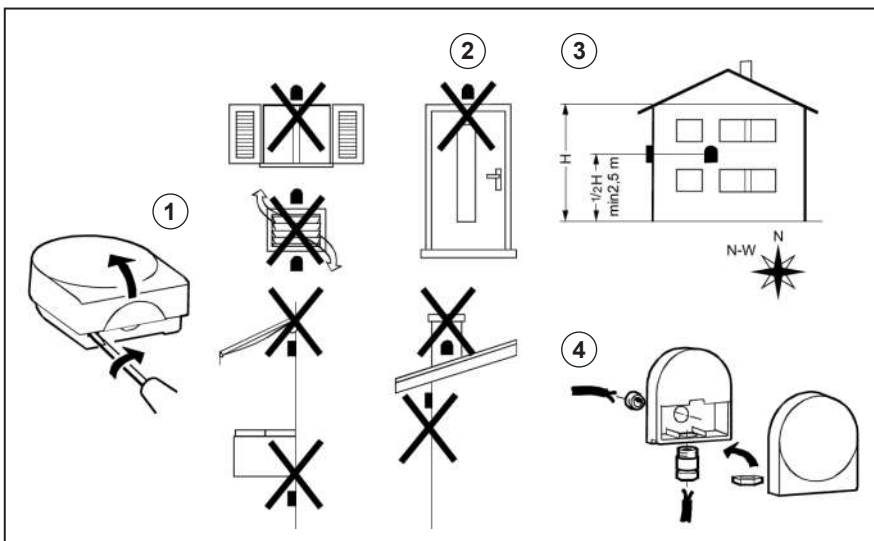

Installation of outdoor sensor

If an outdoor sensor is connected to the boiler, then the sensor must be positioned in conformity with the adjacent drawing.

If an outdoor sensor is NOT connected please refer to PADIN configuration in External control.

Installation

Electrical connection

The boiler has 4 socket blocks for all electrical connections:

1. High voltage supply (230V)
2. Voltage free switches (230V relays)
- 3-4. Low voltage sensors and I/O
5. Communication bus for cascaded R1000 boilers



Caution:

After removing the panels 230V parts can be reached. Electrical connections are only to be carried out by qualified staff.

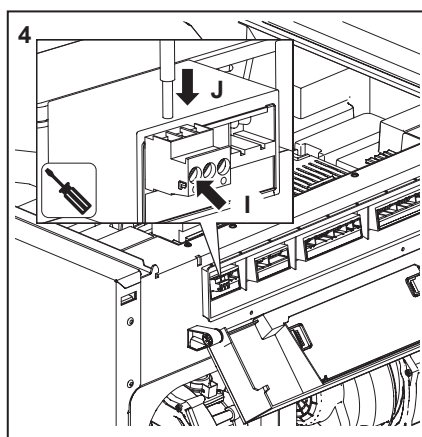
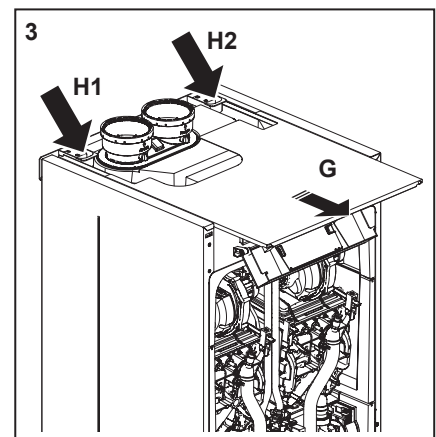
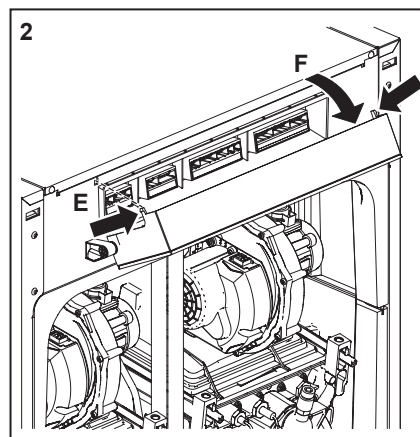
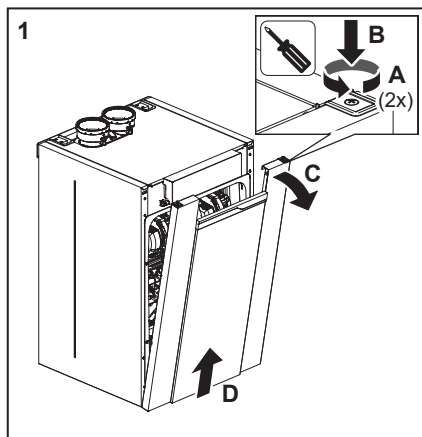
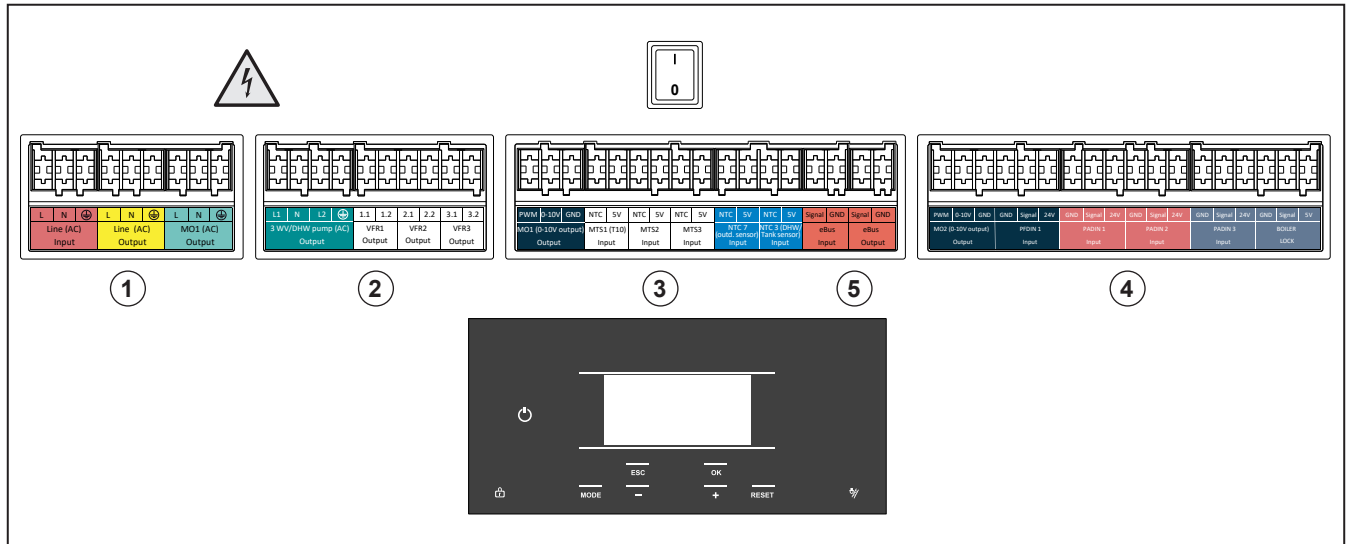

Electrical connections above can be reached following the steps below:

1. Remove the front panel.
2. Press both external sides of the control unit HMI (E) and rotate the display (F).
3. Slide the top panel to the front and use the entrance at the back of the boiler to insert the cables (H1 for high voltage cable, H2 for low voltage cable).
4. Connect the cable with screw connectors already in the socket blocks.

Installation

Electrical connection

1

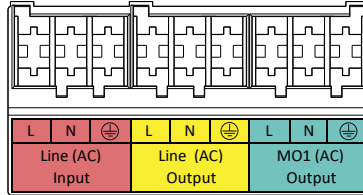

Contact	Line Type		Name	Function Description	Electrical Description
1	Line	Line (AC)	Main input	The Main Power supply to the boiler	230V (+10%; -15%) @50Hz
2	Neutral				
3	Earth				
4	Line	Line (AC)	Main Output	Output of the main power input, Live when the switch of the boiler is on	230V (+10%; -15%) @50Hz ; 7A max
5	Neutral				
6	Earth				
7	Line	MO1 (AC)	MO1 System pump	will run with the boiler pump of the master	230/120VAC; 1A max (80A inrush max); Live switched
8	Neutral				
9	Earth				

2

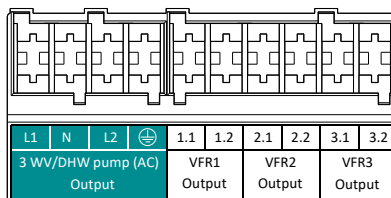

Contact	Line Type		Name	Function Description	Electrical Description
1	Line	3 WW/DHW pump	3 way Valve	Active CH	230/120 VAC; 1A max Fused
2	Neutral		3 way Valve/P2		
3	Line		P2 / 3 way valve	Active for DHW	
4	Earth		Protective Earth		
5	1.1	VFR1	Voltage Free Contact 1	a.i. HC1 pump	230VAC 2A max 80A inrush max not fused
6	1.2				
7	2.1	VFR2	Voltage Free Contact 2	a.i. Alarm Output	230VAC 1A max (cos phi > 0.8) not fused
8	2.2				
9	3.1	VFR3	Voltage Free Contact 2	a.i. Lpg shutoff valve	230VAC 1A max (cos phi > 0.8) not fused
10	3.2				

Installation

Electrical connection

3 & 5

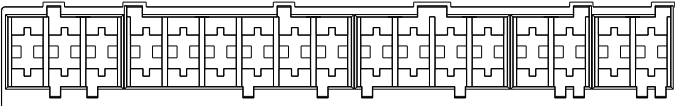

PWM 0-10V	GND	NTC 5V	NTC 5V	NTC 5V	NTC 5V	NTC 5V	NTC 5V	NTC 5V	NTC 5V	Signal	GND	Signal	GND
MO1 (0-10V output)		MTS1 (T10)	MTS2	MTS3	NTC 7 (outd. sensor)	NTC 3 (DHW/Tank sensor)				eBus		eBus	
Output		Input	Input	Input	Input	Input				Input		Output	

Contact	Line Type		Name	Function Description	Electrical Description
1	PWM	MO1	Multifunctional Output 1	DHW pump modulator System Pump Modulator Tank Filling pump Modulator 0..10 Volt feedback to BMS	PWM: 0,1÷4 kHz; Vhigh= 12V; Vlow≤ 0,7V; Ihigh ≤ 10 mA 0..10 Volt
2	0-10 Volt				
3	GND				
4	NTC input	MTS1	Multifunctional Temperature Input 1	T10	NTC 10k β=3977
5	5 Volt				
6	NTC input				
7	5 Volt	MTS2	Multifunctional Temperature Input 2	i.a. Buffer tank top/bottom DHW circulation sensor*	NTC 10k β=3977
8	NTC input				
9	5 Volt				
10	NTC input	MTS3	Multifunctional Temperature Input 3	i.a. Buffer tank top/bottom DHW charging sensor*	NTC 10k β=3977
11	5 Volt				
12	NTC input				
13	5 Volt	NTC7	Outdoor sensor (T4)	Dedicated temperture sensor for outdoor	NTC 1k β=3977
11	5 Volt				
12	NTC input	NTC3	Tank Sensor (T3)	Dedicated temperture for DHW temperature	NTC 10k β=3977
13	5 Volt				
14	Signal	eBus Input	eBus2	Communication bus for i.a. cascade communication / thermostat / clib-in	
15	GND				
16	Signal	eBus Output	eBus2	Communication bus for i.a. thermostat / clib-in	
17	GND				

4

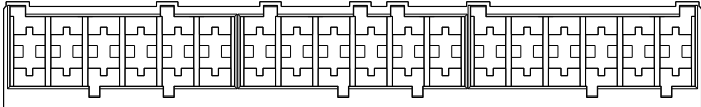

PWM 0-10V	GND	GND	Signal	24V	GND	Signal	24V	GND	Signal	24V	GND	Signal	24V	GND	Signal	24V	GND	Signal	5V
MO2 (0-10V output)			PFDIN 1		PADIN 1		PADIN 2		PADIN 3									BOILER	
Output			Input		Input		Input		Input									LOCK	

Contact	Line Type		Name	Function Description	Electrical Description
1	PWM	MO2	Multifunctional Output 2	System Pump Modulator Tank Filling pump Modulator 0..10 Volt feedback to BMS*	PWM: 0,1÷4 kHz; Vhigh= 12V; Vlow≤ 0,7V; Ihigh ≤ 10 mA 0..10 Volt
2	0-10 Volt				
3	GND				
4	GND	PFDIN 1	Programmable Frequency Digital Input	DHW Flow meter or on/off signal	GND Digital: close with +24Vdc; Frequency 0÷24V; max 400 Hz Power supply: +24Vdc, 10mA max
5	Signal				
6	24 Volt	PADIN 1	Programmable Analog Digital Input 1	i.a. Heat generation lock External consumer request Room Thermostat 1*	GND Digital: close with +24Vdc; Analog: 0÷10V Power supply: +24Vdc, 10mA max
7	GND				
8	Signal				
9	24 Volt	PADIN 2	Programmable Analog Digital Input 2	i.a. 0,,10 Volt temperture request / power request Room Thermostat 2*	GND Digital: close with +24Vdc; Analog: 0÷10V Power supply: +24Vdc, 10mA max
10	GND				
11	Signal				
12	24 Volt	PADIN 3	Programmable Analog Digital Input 3	i.a. Heat generation lock External consumer request Room Thermostat 3*	GND Digital: close with +24Vdc; Analog: 0÷10V Power supply: +24Vdc, 10mA max
13	GND				
14	Signal				
15	24 Volt	BOILER LOCK	BOILER LOCK	Locking input normally closed (bridged)	GND Digital: close with +5Vdc; Analog: 0÷5V Power supply: +5Vdc, 10mA max
16	GND				
17	Signal				
18	5 Volt				

Installation

Electrical connection Temperature sensors

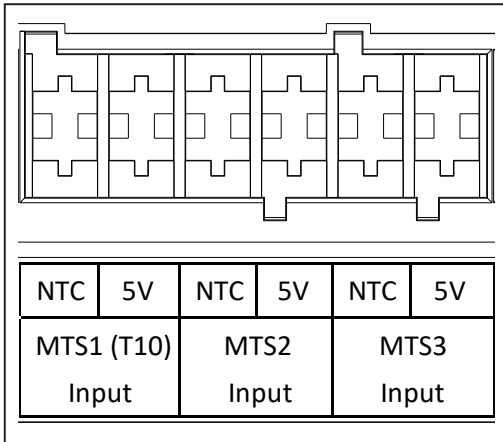

Common flow sensor

When a Common flow sensor is used (for cascade mandatory) it should be addressed on MTS1.

DHW Tank Setting

There are several schemes for hot water preparations see pages 42-45.

Flue gas Sensor

Sensors can also be used as flue gas sensor. With a setting for max temp and system has to switch off or a set temp where system has to reduce the power.

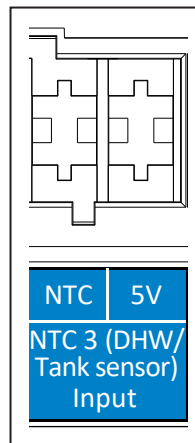
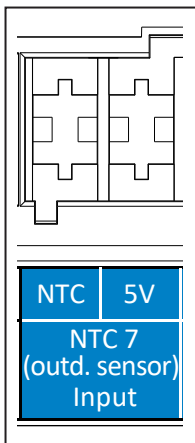

Weather dependent regulation

When WDR is used an outdoor sensor is needed. Keep in account this is a 1K sensor.

This control setting has to be selected and is not auto detect.

Basis DHW preparation

For basic DHW preparation there is a dedicated Tank sensor. For the other regulations the tank sensor is the Top Sensor. Take in account this is a 10K sensor.

Installation

Electrical connection External controls

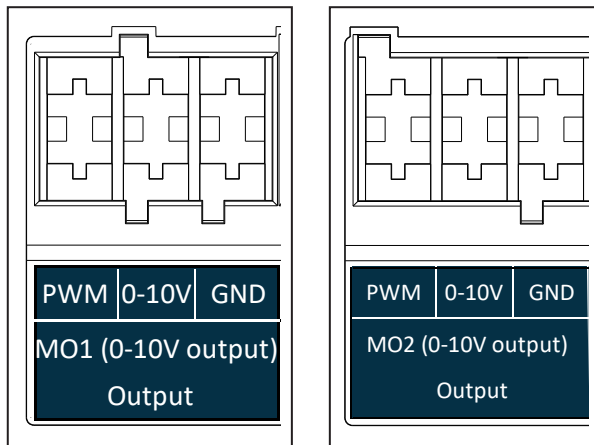

BMS Feedback

For giving feedback to the BMS system this output gives a 0-10 Volt signal as indication of Load.

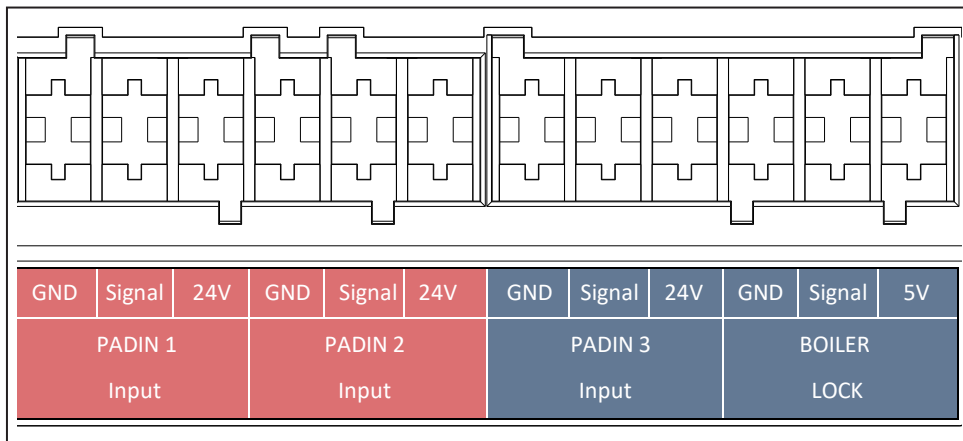

On/Off heat request

Input can be used for on/off control up to 3 zones.

0-10 Volt input (Padin 1-2-3)

Load and temp control via an 0-10 Volt dc input. When 0-10 Volt is selected the system can only be controlled with this system.

HCS + DHW changeover

External controller selects if the system can only be active for DHW or for CH and DHW

Heat Generation Lock

As long as the input is Closed all heat requests are blocked. When applied on PADIN 1 complete cascade will be blocked.

Gas pressure switch

As long as the input is Open all burning actions are blocked. When applied on PADIN 1 complete cascade will be blocked.

BOILER LOCK

Take in account BOILER LOCK is 5 Volt max where 1, 2 & 3 are 24 Volt. Locking input normally closed. Bridge applied from factory. When applied on Cascade master complete cascade will be blocked. Reset is needed.

Installation

Electrical connection eBus2 controls

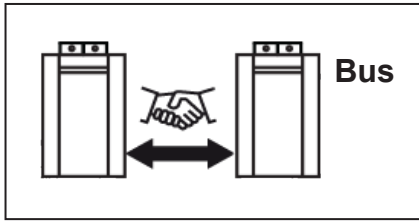

Cascade connection

The connection between boilers in a cascade is done via the eBus2 in and output.

Accessories

To connect accessories like zone clip-in, solar manager, cube etc., use the eBus2 connection.

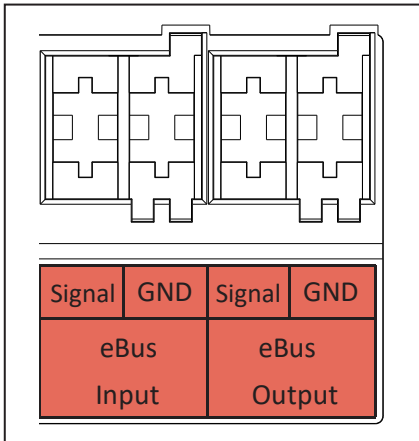

Installation

Electrical connection Wiring diagram

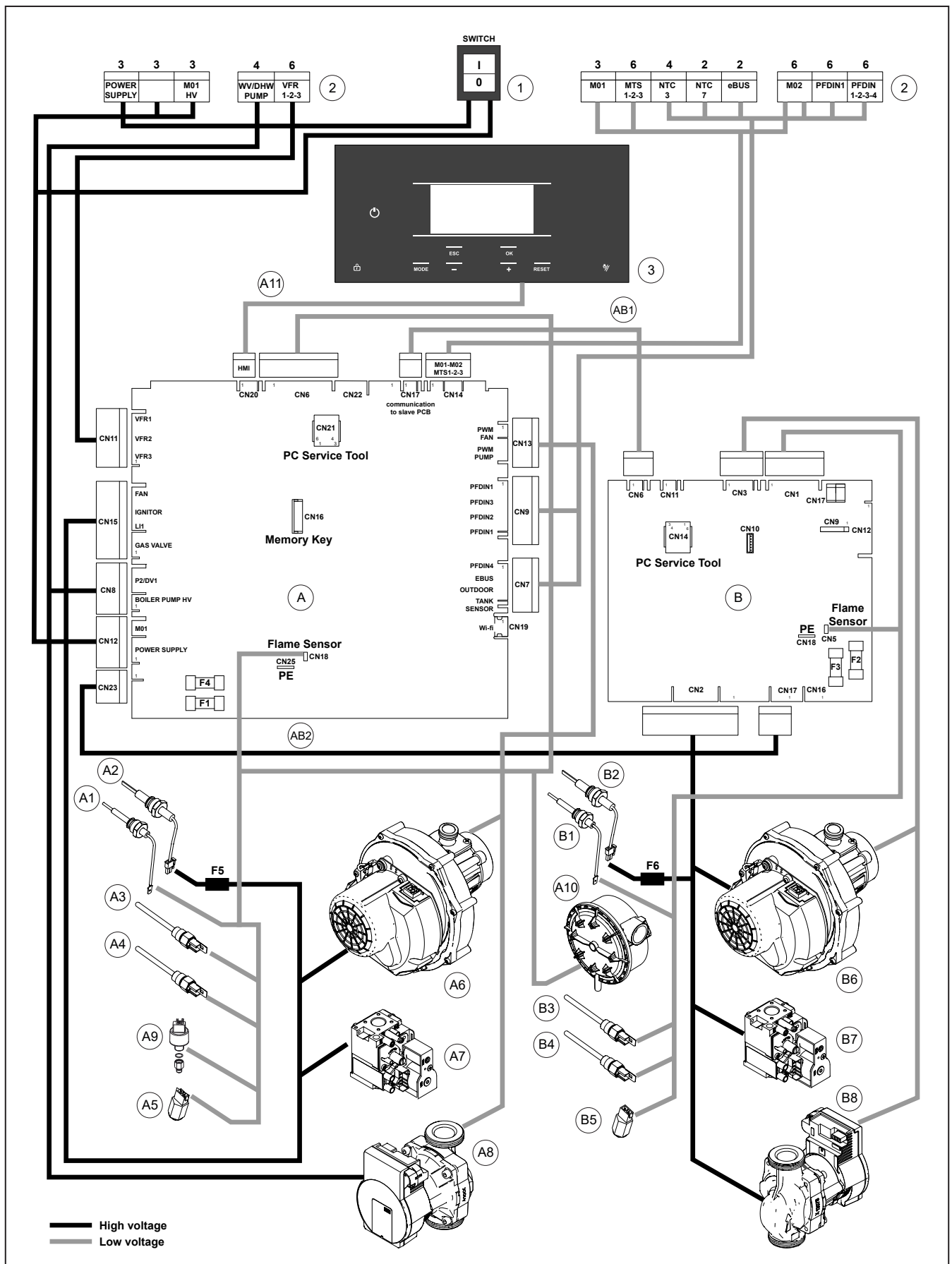

Installation

Electrical connection Wiring diagram

Legend:

1	Main switch 230V
2	Electrical connections
3	Human machine interface HMI
A	Master printed circuit board
A1	Detection electrode
A2	Ignition electrode
A3	Flow sensor T1
A4	Secondary flow sensor T1a
A5	Return sensor T2
A6	Fan unit
A7	Gas valve
A8	Circulation pump
A9	Water pressure sensor P1
A10	Air pressure switch APS
A11	HMI communication cable low voltage
B	Slave printed circuit board
B1	Detection electrode
B2	Ignition electrode
B3	Flow sensor T1
B4	Secondary flow sensor T1a
B5	Return sensor T2
B6	Fan unit
B7	Gas valve
B8	Circulation pump
AB1	Slave low voltage communication cable
AB2	Slave power supply cable
F1	Fuse 6,3A - 250V
F2	Fuse 6,3A - 250V
F3	Fuse 3,15A - 250V
F4	Fuse 3,15A - 250V
F5	Fuse 2A - 250V - 4,2 I ² t - fast
F6	Fuse 2A - 250V - 4,2 I ² t - fast

Installation

Filling the system

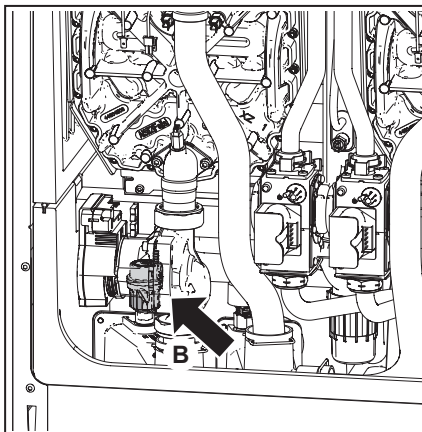
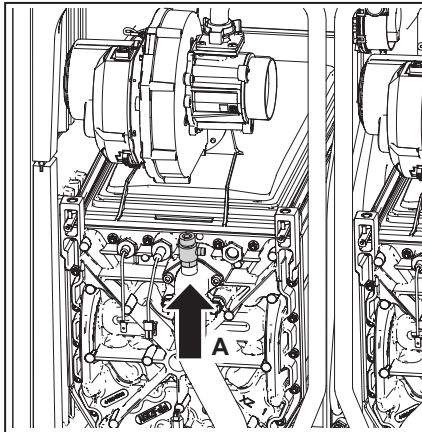
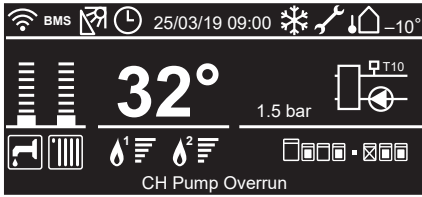

Filling the system

The central heating installation needs to be filled with potable water according to the requirements in chapter 'Water quality'. When the boiler has been electrically commissioned, then the heating system can be filled. For filling or topping up the installation use the following procedure:

1. Connect a filling tap to the return of the hydraulic circuit and open it.
2. Connect a hose on the manual deaerator (A) and open it to remove the air.
3. Close the manual deaerator when water is constantly coming out from it.
4. Slowly fill the central heating system up to 1.5 – 2 bar, Digital pressure reading is shown in the middle of the Home screen.
5. Close the filling tap.
6. Vent the entire heating installation starting at the lowest point.
7. Check the water pressure and top up if necessary to 1.5 – 2 bar.
8. Disconnect the filling tap from the hydraulic circuit.

When powering up the boiler an automatic air purge program will run to vent the boiler ('Airpurge active'). This will last for approximately 7 minutes. During this program the pressure in the central heating needs to be checked, and when necessary, topped up again.

It may take some time before all the air has disappeared from a filled installation. Certainly during the first week sounds may be audible that indicate air. The automatic air vent (B) in the boiler will let this air escape, causing the water pressure to drop during this period and water will need to be refilled again.

Hot water supply

Fill the hot water supply by opening the cold mains isolation valve. Bleed the hot water installation by opening all hot water taps one at a time. Leave each tap to run until all air has disappeared from the supply. Flush with a minimum of 10 litres to rinse any residual contaminants from the hot supply and boiler.

Boiler setting

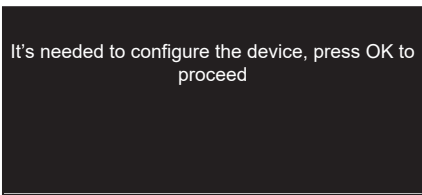

It's needed to configure the device, press OK to proceed

First time startup a boiler

When a boiler is activated there is a question as in the picture on the left. After pressing **OK** the next menu is shown.

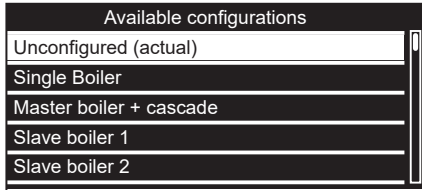

Available configurations

- Unconfigured (actual)
- Single Boiler
- Master boiler + cascade
- Slave boiler 1
- Slave boiler 2

Single boiler setting

When there is no cascade, select “**Single boiler**”. The system will automatically load all needed parameters for a single boiler; if it is a double engine the engine will automatically set.

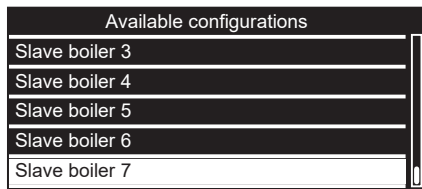

Available configurations

- Slave boiler 3
- Slave boiler 4
- Slave boiler 5
- Slave boiler 6
- Slave boiler 7

Cascade Setting

If the boiler is part of a cascade installation, select “**Master boiler + cascade**” and confirm the selection by pressing the **OK** button. You will then be prompted to configure the appliance as either a master or slave unit and configure the address.

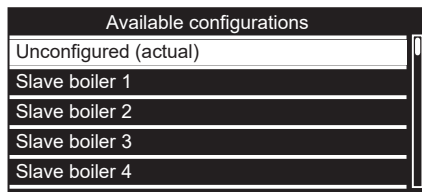

Available configurations

- Unconfigured (actual)
- Slave boiler 1
- Slave boiler 2
- Slave boiler 3
- Slave boiler 4

Operation

Description of display

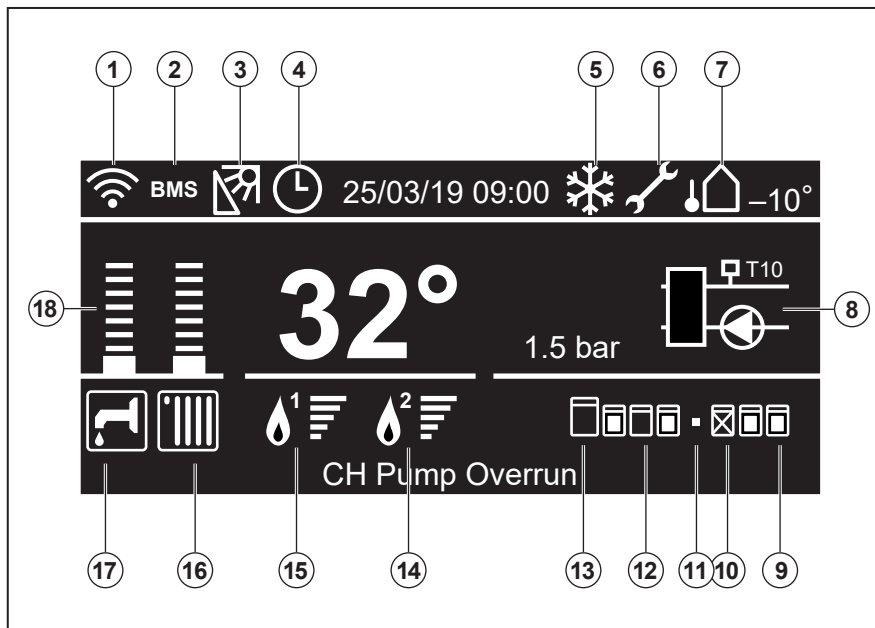

















The boiler has a pilot-control. This control takes care of most of the manual settings but also provides numerous settings to adjust the control exactly to the installation and user requirements.

Display

The LCD screen has a backlight. Activate the display first before it will accept an action. The light is activated by pushing one of the buttons.

Cascade symbols are not visible in case of a single boiler or when no bus communication cable is connected.

Screen explanation

	1. WIFI Gateway presence and status		11. No slave boiler connected
BMS	2. Building Management System detected		12. Slave boiler in stand by mode
	3. Solar Manger presence		13. Master boiler
	4. Operation Mode = TIME BASED on the «zone to Show» zone		14. Engine 2 Flame presence and power <i>Slave engine (if present) is active.</i>
	5. Pump Continuous function		15. Engine 1 Flame presence and power <i>Main engine is active.</i>
	6. Maintenance Warning present		16. DHW enable and heating request <i>Boiler or Cascade system controls Central Heating. If there is a square around the symbol, then the system is active for Central Heating.</i>
	7. Outdoor Temperature		17. CH enable and heating request <i>Boiler or Cascade system controls Domestic Hot Water. When there is a square around the symbol, then the system is active for Domestic Hot Water.</i>
	8. System Pump status <i>T10 means T10 is present. When the pump symbol is flashing, the relay on block 1 contact 3 is closed.</i>		18. CH/DHW actual SetPoint relative level
	9. Slave boiler on (heating mode)		
	10. Slave boiler in error mode		

Operation

Description of display and keyboard

Boiler status

C.Heating active
 Storage active
 CH pump overrun
 DHW Pump overrun
 Pump frost prot
 Burn frost prot
 Storage frost prot
 Thermal Cleanse in progress
 DHW serving from solar
 Heat generation lock
 Chimney active
 Air purge active

Status description

Burner active for heating
 Burner active for Storage Tank
 Overrun time pump over CH
 Overrun time pump over DHW
 Pump active for frost protection
 Burner active for frost protection
 Burner active for Tank Frost protection
 AntiLegionella cycle in progress
 DHW request serving from solar
 Burner inactive for boiler heat generation lock
 Burner in service mode stage
 Pump in air purge stage

Boiler mode and power button color:

The Power Button has four colors:

- White: boiler is off (using power button).
- Green: boiler is on (using power button), but not active (no heating).
- Blue: boiler is on and active (heating).
- Red: there is an error.

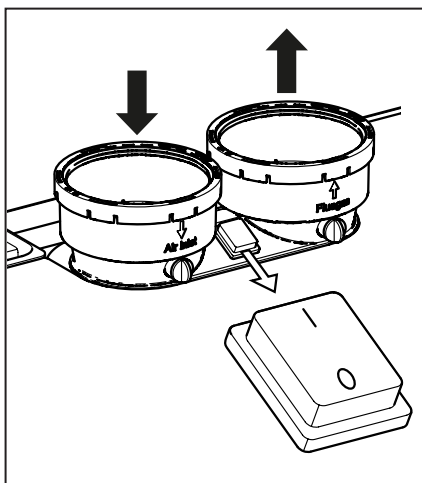
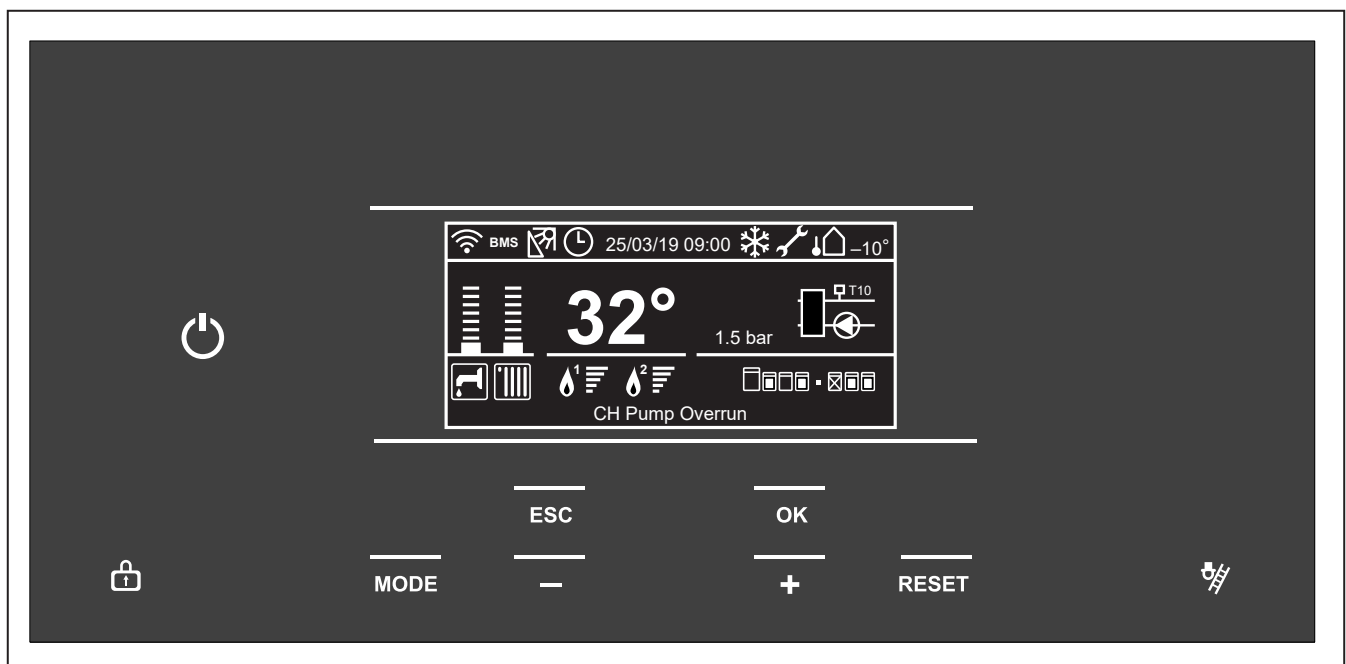



The keyboard consists of a logical button allocation for menu control, confirmation, and correction and emission measurement.

* Reset only functions in case of an Error or Message.

Recommendation: First identify the fault by finding the fault code in the fault-code list in the problem-shooting chapter and solve the problem.

The main switch is located on top of the boiler between the air supply and the flue connection. This switch controls the 230V power supply (L and N).

Description of the keyboard:

-  Power button
-  Display lock/unlock
- MODE** Mode
- ESC** Escape / back / correction
- Value decrease / down / left
- +** Value increase / up / right
- OK** Confirm selection
- RESET** Reset
-  Chimney sweeper mode

Operation

Structure of the User Menu

The device functions are divided into three levels, depending on their importance and the frequency of their use.

- 1 Home screen
- 2 Basic settings menu
- 3 Complete menu

Home screen

This menu is used to display the operating status of the system and to set the desired room temperature by simply turning the knob.

Basic settings menu

In this menu, the main functions can be accessed by selecting the manual or programming and operating mode (summer/winter/off).

Complete menu

This menu can be used to access all main system parameters and set/adjust the time program and home screen.

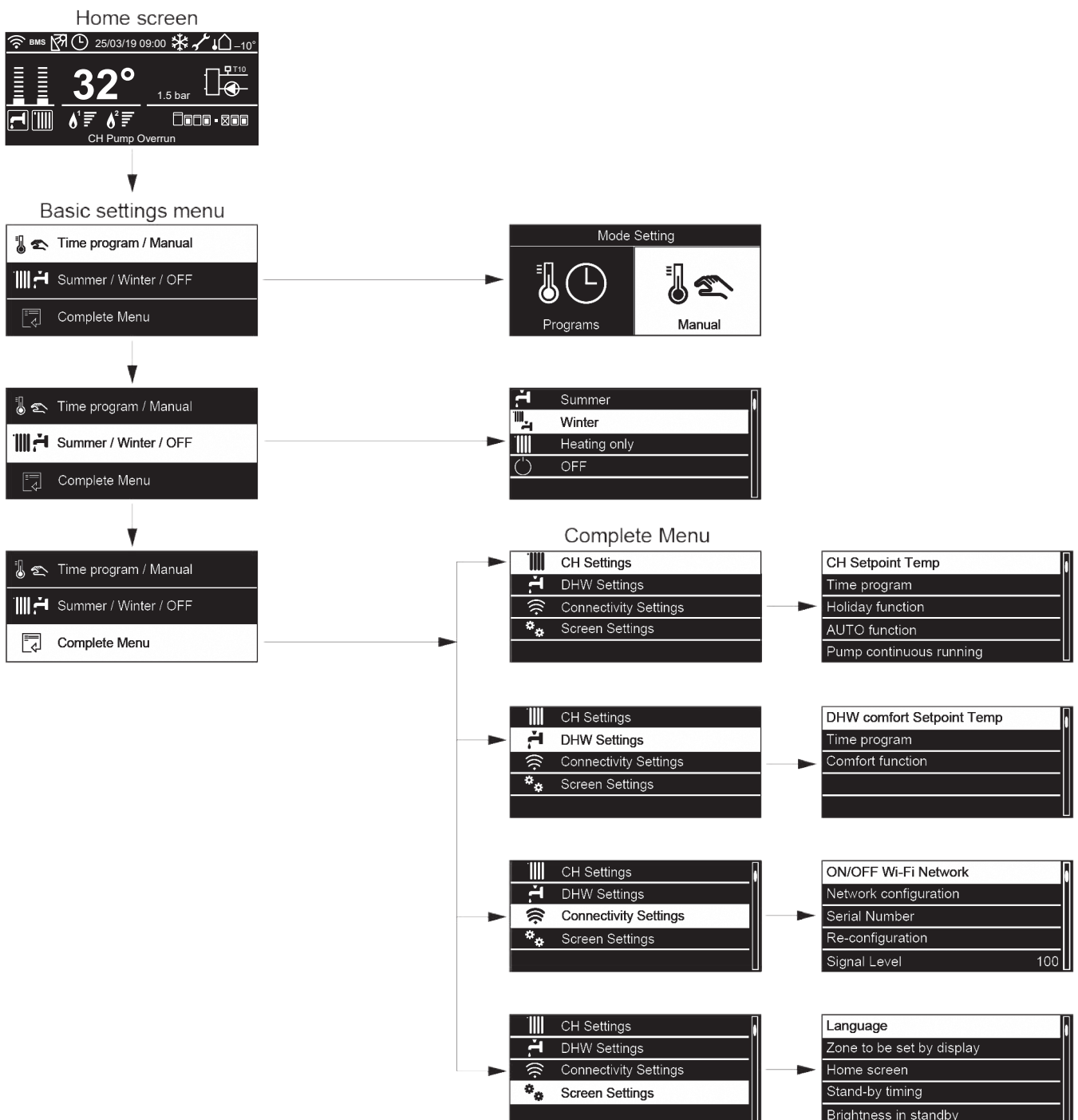

Operation

Change the settings (expert level)

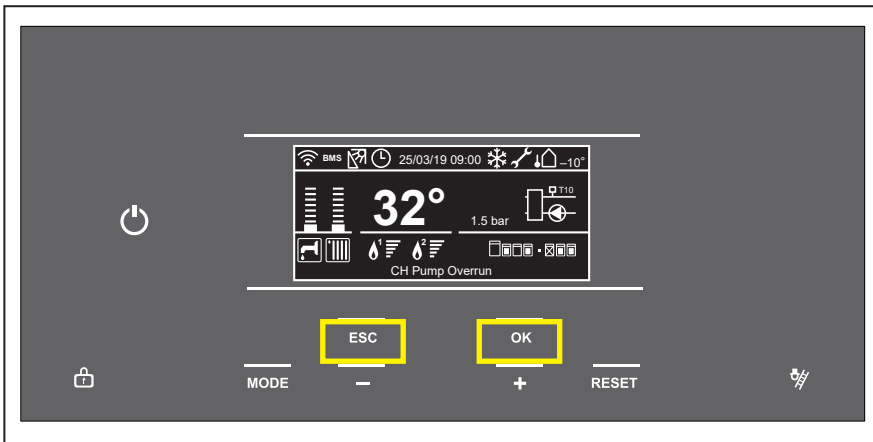

The settings are accessible through a code.

- 1 From the controller Home screen, press the **ESC** and **OK** buttons at the same time for 7 seconds.



- 2 Use “+” to go down and “-” to go up to highlight **007** as the Technical Code. Press **OK**.

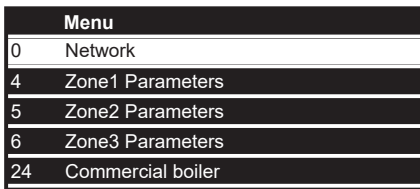

- 3 Use “+” to go down and “-” to go up to highlight **Complete Menu**. Press **OK**. It is now loading the menu.

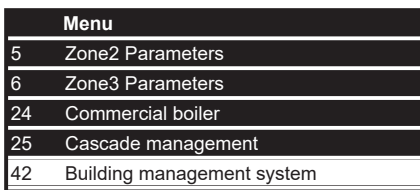

The screen left appears.

This way you have access to the complete parameter level.

In the table hereafter you will find a complete overview of all available Parameters

Operation

Parameter listing

Menu	Submenu	Parameter	Name	Description	Range	Factory settings
0	NETWORK					
0.	2	BUS Network				
0.	2.	0	Network Presence	Indication of devices connected via BUS	Boiler Zone Clipin Remocon Gateway	1
			Boiler Configuration	0=Undefined 1=Single Boiler 2=Master Boiler + cascade 3=Slave Boiler 1 4=Slave Boiler 2 5=Slave Boiler 3 6=Slave Boiler 4 7=Slave Boiler 5 8=Slave Boiler 6 9=Slave Boiler 7	0-9	0
0.	4	User interface				
0.	4.	0	Zone to be set by display		1 - 3	1
0.	4.	1	Backlight timing		1 min - 24 hours	10 min
0.	4.	3	Time Program service type		0 - 1	1
0.	4.	4	Reset System Interfce	OK = Yes, BACK = No		
4	Zone1 Parameters					
4.	0	Setpoint				
4.	0.	0	T Day	Room temperature set point for day period	10 - 30 (°C)	21
4.	0.	1	T Night	Room temperature set point for night period	10 - 30 (°C)	16
4.	0.	2	T set Z1	Temperature setpoint zone 1 (Limited by Para 4.2.5 and Para 4.2.6)	4.2.5 4.2.6	HT 70
4.	0.	3	Zone frost temperature		2 - 15 (°C)	5
4.	1	Summer/Winter Changeover				
4.	1.	0	Automatic winter mode activation	0 = OFF, 1 = ON (only active when outside temperature influence)	0 - 1	0
4.	1.	1	Automatic winter mode threshold		0 - 30 (°C)	20
4.	1.	2	Automatic winter mode delay time	Time before S/W changeover becomes active	0 - 300 (min)	60
4.	2	Zone1 Settings				
4.	2.	0	Zone temperature range	0 = Low Temp (LT) 1 = High Temp (HT)	0 - 1	1
4.	2.	1	Thermoregulation	0 = Fix Flow T 1 = Basi Thermoreg 2 = Room T Only 3 = Outdoor T Only 4 = Room+Outdoor T	0 - 4	0

Operation

Parameter listing

Menu	Submenu	Parameter	Name	Description	Range	Factory settings	
4.	2.	2	Slope		LT: From 0.2 - 1.0 HT: From 0.4 - 3.5	0.6LT 1.3HT	
			<p>Increase setting: Increases the flow temperature, especially at low outside temperatures.</p> <p>Reduce setting: Reduces the flow temperature, especially at low outside temperatures.</p>				
4.	2.	3	Offset	Offset heating line adjustable per °C	LT: From -7°C to +7°C HT: From -14°C to +14°C	0 0	
4.	2.	4	Room influence proportional	Only visible on the boiler if a room sensor is connected		LT=2 HT=4	
4.	2.	5	Max T	Zone 1 maximum Flow Temperature	LT: From 10°C to 45°C HT: From 10°C to 90°C	LT 45 HT 85	
4.	2.	6	Min T	Zone 1 minimum Flow Temperature	LT: From 10°C to 45°C HT: From 10°C to 90°C	LT 20 HT 20	
4.	2.	7	Thermo regulation logic	0 = Classic, 1 = Smart	0 - 1	0	
4.	2.	8	Quick night setback	0 = OFF, 1 = ON	0 - 1	0	
4.	2.	9	Heat request mode	0 = Standard 1 = RT Time Programs Exclusion 2 = Forcing Heat Demand	0 - 2	1	
4.	3.	Zone1 Diagnostics					
4.	3.	0	Room T		°C		
4.	3.	1	Room T setpoint		°C		
4.	3.	2	Flow temperature		°C		
4.	3.	3	Return temperature		°C		
4.	3.	4	Heat request Z1		0 = OFF, 1 = ON		
4.	3.	5	Pump status		0 = OFF, 1 = ON		
4.	3.	8	Zone flow temperature setpoint		°C		
4.	3.	9	Heating rate				

Operation

Parameter listing

Menu	Submenu	Parameter	Name	Description	Range	Factory settings
4.	7	Zone regulation parameters				
4.	7.	0	Heating Type	0 = Floor Heating 1 = Radiators 2 = Floor Heating (main)+ radiators 3 = Radiators(main)+ Floor Heating 4 = Convection 5 = Air Heating	0 - 5	1
4.	7.	1	Room Influence	0 = Off 1 = Less 2 = Medium 3 = More	0-3	0
4.	7.	2	Building Isolation Level	0 = Poor 1 = Average 2 = Good	0-2	0
4.	7.	3	Building Size	0 = Small 1 = Average 2 = Large	0 - 2	0
4.	7.	4	Climatic Zone		+50 to -60 °C	-10
4.	7.	5	Auto Slope Adaptation	0 = OFF 1 = ON	0 - 1	0
4.	7.	6	Pre-Heating Function	0 = OFF 1 = ON	0 - 1	0
5	Zone2 Parameters (see Zone1, chapter 4)					
6	Zone3 Parameters (see Zone1, chapter 4)					
14	Zone4 Parameters (see Zone1, chapter 4) when second Zone module clip 3 is applied					
15	Zone5 Parameters (see Zone1, chapter 4) when second Zone module clip 3 is applied					
16	Zone6 Parameters (see Zone1, chapter 4) when second Zone module clip 3 is applied					
20	Buffer					
20.	0	Configuration				
20.	0.	0	Buffer Activation	0 = OFF 1 = ON	0 - 1	0
20.	0.	1	Buffer charge mode	0 = Not defined 1 = Partial charge 2 = Full charge	0 - 1	1
20.	0.	2	Buffer setpoint temperature hysteresis		0 - 20 °C	5°C
20.	0.	3	Buffer heating Comfort setpoint temperature		20 - 70°C	40°C
20.	0.	4	Buffer cooling Comfort setpoint temperature		5 - 23°C	18°C
20.	0.	7	Buffer setpoint mode	0 = Fixed 1 = Variable	0 - 1	0 - 1
20.	0.	8.	Buffer hysteresis cooling		°C	[0; 20]

Operation

Parameter listing

Menu	Submenu	Parameter	Name	Description	Range	Factory settings
20.	1	Diagnostics				
20.	1.	0	Low sensor temperature		°C	
20.	1.	2	High sensor temperature		°C	
20.	4	System settings				
20.	4.	0	Buffer Integration Scheme	0 = Series 1 = Parallel	0 - 1	
20.	4.	1	Buffer Solar Integration	0 = No 1 = Yes	0 - 1	
24	Commercial Boiler					
24.	0	General				
24.	0.	1	Gas type	0 = NG, 1 = LPG	0 - 1	0
24.	0.	2	Maximum Water temp		20 - 95 °C	90
24.	0.	3	Max CH Adjustable		0 - 100 %	100
24.	0.	5	Altitude		0 - 1000 m	0
24.	0.	6	Boiler tank solar integration	0 = Absent 1 = Present	0 - 1	0
24.	0.	7	Emergency setpoint		20 - 90 °C	45
24.	0.	8	Max DHW adjustable		0-100 %	100
24.	0.	9	Boiler model	0 = Not defined 1 = 60kW 2 = 70/75kw 3 = 100/105kw 4 = 120/125kW 5 = 140/150kW 6 = 170/180kW 7 = 200/210kW	Depending on boiler type	Also Depending on boiler type
24.	3.	Water Circulation				
24.	3.	0	Max PWM Pump		46 - 95 %	95
24.	3.	1	Min PWM Pump		40 - 95 %	46
24.	3.	2	CH pump overrun		0 - 16 min.	5
24.	3.	3	Max pressure		2.0 - 6.0 bar	6.0
24.	3.	5	Delta T pump control		20 - 25°C	20
24.	4.	System Setting				
24.	4.	1	External temperature correction		-3 to +3°C	0
24.	4.	2	Boost Time		0 - 60 min	16
24.	4.	3	Plant frost protection	0 = OFF 1 = ON	0 - 1	0
24.	4.	4	T Gradient		0 - 15°C	5
24.	4.	5	System Pump Overrun		0 - 255 min	5
24.	4.	6	System pump activation logic	0 = Always active 1 = Heating only	0 - 1	0
24.	4.	7	System tank solar integration	0 = Absent 1 = Present	0 - 1	0
24.	4.	8	CH/DHW shifting priority time		0 - 65535	0
24.	4.	9	HC pump overrun DHW		0 - 1	0

Operation

Parameter listing

Menu	Submenu	Parameter	Name	Description	Range	Factory settings
24.	5	Domestic Hot Water				
24.	5.	0	DHW Setpoint Temperature		20 - 80 °C	60
24.	5.	1	Comfort Function	0 = Disabled 1 = Time Based 2 = Always Active	0 - 2	2
24.	5.	2	System DHW Mode	0 = CH Only 1 = Storage with NTC 2 = Storage with Thermostat	0 - 2	0
24.	5.	3	Boiler DHW Mode	0 = CH Only 1 = Storage with NTC 2 = Storage with Thermostat	0 - 2	0
24.	5.	4	Thermal cleanse function	0 = OFF 1 = ON	0 - 1	1
24.	5.	5	Boiler Tank charge mode	0 = Charge 1 = Full charge 2 = Full charge Legio	0 - 2	0
24.	5.	6	System Tank charge mode	0 = Charge 1 = Full charge 2 = Full charge Legio	0 - 2	0
24.	5.	7	Boiler DHW Circulating Pump Release	0 = Release 1 = Time Program 2 = Special Time Program	0 - 2	0
24.	5.	8	System DHW Circulating Pump Release	0 = Release 1 = Time Program 2 = Special Time Program	0 - 2	0
24.	5.	9	System DHW Charging Priority	0 = Absolute 1 = Shift 2 = None	0 - 2	0
24.	6	Configurable Inputs-Outputs				
24.	6.	0	Multi In Temp 1	0 = None 1 = Common flow sensor 2 = DHW storage tank bottom 3 = DHW circulation sensor 4 = DHW charging sensor 5 = Buffer storage tank top 6 = Buffer storage tank bottom 7 = Flue gas temp sensor	0 - 7	1
24.	6.	1	Multi In Temp 2	0 = None 1 = Common flow sensor 2 = DHW storage tank bottom 3 = DHW circulation sensor 4 = DHW charging sensor 5 = Buffer storage tank top 6 = Buffer storage tank bottom 7 = Flue gas temp sensor	0 - 7	0

Operation

Parameter listing

Menu	Submenu	Parameter	Name	Description	Range	Factory settings
24.	6.	2	Multi In Temp 3	0 = None 1 = Common flow sensor 2 = DHW storage tank bottom 3 = DHW circulation sensor 4 = DHW charging sensor 5 = Buffer storage tank top 6 = Buffer storage tank bottom 7 = Flue gas temp sensor	0 - 7	0
24.	6.	4	PADIN 1 input	0 = None 1 = Room thermostat HC1 ON/OFF/ 2 = Room thermostat HC2 ON/OFF/ 3 = Room thermostat HC3 ON/OFF/ 4 = 0- 10V input request (BMS) 5 = DHW time input 6 = Heat generator lock - applies for complete cascade 7 = Gas Pressure Switch - applies for complete cascade 8 = CH timer input	0 - 8	0
24.	6.	5	PADIN 2 input	0 = None 1 = Room thermostat HC1 ON/OFF/ 2 = Room thermostat HC2 ON/OFF/ 3 = Room thermostat HC3 ON/OFF/ 4 = 0- 10V input request (BMS) 5 = DHW time input 6 = Heat generator lock only applies on the boiler (not complete cascade) 7 = Gas Pressure Switch - only applies on the boiler (not complete cascade) 8 = CH timer input	0 - 8	0
24.	6.	6	PADIN 3 input	0 = None 1 = Room thermostat HC1 ON/OFF/ 2 = Room thermostat HC2 ON/OFF/ 3 = Room thermostat HC3 ON/OFF/ 4 = 0- 10V input request (BMS) 5 = DHW time input 6 = Heat generator lock only applies on the boiler (not complete cascade) 7 = Gas Pressure Switch - only applies on the boiler (not complete cascade) 8 = CH timer input	0 - 8	0
24.	6.	7	Boiler lock	Boiler lock. When applied on Cascade master complete cascade will be blocked.	11 - 11	11

Operation

Parameter listing

Menu	Submenu	Parameter	Name	Description	Range	Factory settings
24.	7	Configurable Inputs-Outputs 2				
24.	7.	0	Multi Out HV	0 = None 1 = System pump 2 = HC1 Pump 3 = Circulating pump 4 = DHW intermediate circuit pump 5 = BUF filling pump 6 = Storage tank transfer pump	0 - 6	0
24.	7.	1	VFR 1 output 1	0 = None 1 = System pump (25.1.6) 2 = HC1 Pump 3 = Circulating pump 4 = DHW charging pump (only active with 3-way valve) 5 = BUF filling pump 6 = Storage tank transfer pump 7 = Heat generation shutoff valve 8 = Heat request 9 = Alarm output 10 = LPG/ Room Supply Fan	0 - 10	0
24.	7.	2	VFR 2	0 = None 1 = Heat generation shut off valve 2 = Heat request 3 = Alarm output 4 = LPG/ Room Supply Fan	0 - 4	0
24.	7.	3	VFR 3	0 = None 1 = Heat generation shut off valve 2 = Heat request 3 = Alarm output 4 = LPG/ Room Supply Fan	0 - 4	0
24.	7.	4	MO1 output PWM or 0-10V for BMS	0-10 Volt feedback active only inverted	5 - 5	5
24.	7.	5	MO2 output PWM or 0-10V for BMS	0-10 Volt feedback active only inverted	5 - 5	5
24.	7.	6	Alarm output	0 = Cascade manager error 1 = Engine error volatile 2 = Engine error not volatile 3 = Engine error volatile or not volatile 4 = Boiler error volatile 5 = Boiler error not volatile 6 = Boiler error volatile or not volatile	0 - 6	6
24.	7.	7	Alarm output delay time	Delay time before triggering the alarm output	0 - 255 min.	0

Operation

Parameter listing

Menu	Submenu	Parameter	Name	Description	Range	Factory settings	
24.	8	Boiler manual settings					
24.	8.	0	Manual mode activation				
			OFF ON		0 - 1	0	
24.	8.	1	Boiler pump control				
			OFF ON		0 - 1	0	
24.	8.	2	Fan control				
			0 = OFF 1 = ON		0 - 1	0	
24.	8.	3	Boiler pump control 2nd Engine				
			0 = OFF 1 = ON		0 - 1	0	
24.	8.	4	Fan control 2nd Engine				
			0 = OFF 1 = ON		0 - 1	0	
24.	8.	5	Diverter valve control				
			0 = OFF 1 = ON		0 - 1	0	
24.	8.	6	Multi-Functional Output 1				
			0 = OFF 1 = ON		0 - 1	0	
24.	8.	7	Free Contacts 1,2,3				
			0 = OFF 1 = ON		0 - 1	0	
24.	9	Test and Utilities					
24.	9.	0	Test mode				
			0 = OFF 1 = ON		0 - 1	0	
24.	9.	1	Air-purge function				
			0 = OFF 1 = ON		0 - 1	0	
24.	9.	2	Force Backup				
			0 = OFF 1 = ON		0 - 1	0	
24.	9.	3	Force Restore				
			0 = OFF 1 = ON		0 - 1	0	

Operation

Parameter listing

Menu	Submenu	Parameter	Name	Description	Range	Factory settings	
24.	10	Engine 1 diagnostics					
24.	10.0	0	Fan Speed		rpm		
24.	10.1	1	Pump Modulation %		%		
24.	10.2	2	Ionization current		uA		
24.	10.3	3	Safety flame sensor				
24.	10.4	4	CH flow temperature		°C		
24.	10.5	5	CH flow2 temperature		°C		
24.	10.6	6	CH Return T		°C		
24.	10.7	7	Pump Flow Rate		l/min		
24.	10.8	8	Gas Power		kW		
24.	11	Engine 2 diagnostics					
24.	11.0	0	Fan Speed		rpm		
24.	11.1	1	Pump Modulation %		%		
24.	11.2	2	Ionization current		uA		
24.	11.3	3	SAFETY Flame presence				
24.	11.4	4	CH Flow T		°C		
24.	11.5	5	CH Flow2 T		°C		
24.	11.6	6	CH Return T		°C		
24.	11.7	7	Pump Flow Rate		l/min		
24.	11.8	8	Gas Power		kW		
24.	12	Boiler Diagnostics					
24.	12.0	0	Flue Gas T		°C		
24.	12.1	1	Diverter Valve Pos				
			Hot Water				
			Central Heating				
24.	12.2	2	Heating Circuit Pressure		bar		
24.	12.3	3	Boiler Power level		%		
24.	12.4	4	Storage Temperature - High		°C		
24.	12.5	5	Storage Temperature - Low		°C		
24.	12.6	6	Boiler Status				
24.	13	System Diagnostics					
24.	13.0	0	CH Flow Set T		°C		
24.	13.1	1	System Flow T		°C		
24.	13.2	2	Outdoor T		°C		
24.	13.3	3	Storage Temperature - High		°C		
24.	13.4	4	Storage Temperature - Low		°C		
24.	13.5	5	System Pump Status				
24.	13.6	6	DHW Pump Status				

Operation

Parameter listing

Menu	Submenu	Parameter	Name	Description	Range	Factory settings	
24.	14	Engine 1 Statistics					
24.	14. 0		Number Of Ignition Cycles (n x10)				
24.	14. 1		Hours Burner On (h x10)				
24.	14. 2		Boiler circulator cycles No. (n x10)				
24.	14. 3		Time of circulator on (h x 10)				
24.	14. 4		Fan cycles No. (n x10)				
24.	14. 5		Time of fan ON (h x 10)				
24.	14. 6		Number Of Flame Faults (n x10)				
24.	15	Engine 2 Statistics					
24.	15. 0		Number Of Ignition Cycles (n x10)				
24.	15. 1		Hours Burner On (h x10)				
24.	15. 2		Number of boiler circulator cycles (n x10)				
24.	15. 3		Time of circulator on (h x 10)				
24.	15. 4		Number of fan cycles (n x10)				
24.	15. 5		Time of fan ON (h x 10)				
24.	15. 6		Number Of Flame Faults (n x10)				
24.	16	Boiler Statistics					
24.	16. 0		Life Time (h x 10)				
24.	16. 1		Hours Burner On CH (h x10)				
24.	16. 2		Hours Burner On DHW (h x10)			12	
24.	16. 3		Diverter valve cycles No. (n x10)				
24.	16. 4		Heat Req Duration (h x 10)		min	0	
24.	17	Service					
24.	17. 0		Months to Next Maintenance		0 - 60	12	
24.	17. 1		Mainten On Days Act				
			0 = OFF 1 = ON		0 - 1	0	
24.	17. 2		Maint Warn Reset Reset? OK=Yes,esc=No				
24.	17. 3		SW Version Interface				
24.	17. 4		SW Version Main				
24.	17. 5		SW Version BHE2		To create		
24.	18	Error History					
24.	18. 0		Last 10 Errors				
24.	18. 1		Reset Error List Reset? OK=Yes,esc=No				
24.	19	Reset Menu					
24.	19. 0		Reset Factory Settings Reset? OK=Yes,esc=No				

Operation

Parameter listing

Menu	Submenu	Parameter	Name	Description	Range	Factory settings
24.	20	Other				
24.	20.	0	DHW modulation setpoint		50 - 85	80
24.	20.	1	DHW program mode	0 = DHW time program 1 = Zone 1 2 = Zone 2 3 = Zone 3 4 = Zone 4 5 = Zone 5 6 = Zone 6 7 = Zones 1,2,3 8 = Zones 4,5,6 9 = All zones 10 = Disabled	0 - 10	0
24.	20.	2	Flue gas sensor type	0 = None 1 = NTC 2 = ON/OFF Thermostat	0-2	0
24.	20.	3	Flue gas supervision lockout	0 = Blocking 1 = Error	0-1	0
24.	20.	4	DHW tank discharge protection	ON/OFF	1-0	1
24.	20.	5	Boiler DHW recirculation pump target (active with 3-way valve)	target temp	10 - 90°C	50
24.	20.	6	System DHW recirculation pump target (active with LLH)	target temp	10 - 90°C	50
24.	21	Other 2				
24.	21.	6	Thermal cleanse start time	Starting time for the thermal cleanse cycle	00:00 - 23:45	01:00
24.	21.	7	Thermal cleanse cycle frequency		24 - 480 hour	168
24.	21.	8	Negative Gain Multiplier	Change the speed of the heat Load when T10 > than setpoint	1 - 25	1
24.	23	Free parameters				
24.	23.	2	Boiler free parameters		n.a.	
24.	23.	3	Boiler free parameters		n.a.	
24.	23.	5	Boiler free parameters		n.a.	
24.	23.	6	Boiler free parameters		n.a.	
25	Cascade Management					
25.	0	General				
25.	0.	0	Max CH Adjustable Power perc		0 - 100%	100
25.	0.	1	Max DHW Adjustable Power perc		0 - 100%	100
25.	0.	2	Cascade Turnover Logic	0 = Minimum Switches Off-On 1 = Maximum Power Division	0 - 1	0
25.	0.	3	Turnover Hysteresis		0 - 20%	10
25.	0.	4	Min Turnover Level		0 - 100%	20
25.	0.	5	Max Turnover Level		0 - 100%	50
25.	0.	6	Maximum Water temp		20 - 95°C	90
25.	0.	7	CH differential temperature		0 - 20°C	2
25.	0.	8	CH/DHW shifting priority time		0 - 65535min.	0

Operation

Parameter listing

Menu	Submenu	Parameter	Name	Description	Range	Factory settings
25.	1	System Settings				
25.	1.	1	External temperature correction		-3 - 3°C	0
25.	1.	2	Boost Time		0 - 60min.	16
25.	1.	3	Plant frost protection			
			0 = OFF 1 = ON		0 - 1	0
25.	1.	4	T Gradient		0 -15°C	5
25.	1.	5	System Pump Overrun		0 - 255min.	5
25.	1.	6	System pump activation logic			
			0 = Always active 1 = Heating only		0 - 1	0
25.	1.	7	System tank solar integration			
			0 = Absent 1 = Present		0 - 1	0
25.	1.	8	HC pump overrun DHW		0-1	0
25.	1.	9	DHW tank discharge protection	OFF/ON	0-1	1
25.	2	Domestic Hot Water				
25.	2.	0	DHW Setpoint Temperature		20 - 80°C	60
25.	2.	1	Comfort Function			
			0 = Disabled 1 = Time Based 2 = Always Active		0 - 2	2
25.	2.	2	System DHW Mode			
			0 = CH Only 1 = DHW Tank NTC 2 = DHW Tank Thermostat		0 - 2	0
25.	2.	3	Thermal cleanse function			
			0 = OFF 1 = ON		0 - 1	1
25.	2.	4	System DHW charge mode			
			0 = Charge 1 = Full charge 2 = Full charge Legio		0 - 2	0
25.	2.	5	System DHW Circulating Pump Release			
			0 = Release 1 = Time Program 2 = Special Time Program		0 - 2	0

Operation

Parameter listing

Menu	Submenu	Parameter	Name	Description	Range	Factory settings
25.	2.	6	System DHW Charge Priority			
			0 = Absolute 1 = Shift 2 = None		0 - 2	0
25.	2.	7	DHW modulation setpoint		50 - 85°C	80
25.	2.	8	DHW differential temperature		°C	5
25.	2.	9	DHW program mode	0 = DHW time program 1 = Zone 1 2 = Zone 2 3 = Zone 3 4 = Zone 4 5 = Zone 5 6 = Zone 6 7 = Zones 1,2,3 8 = Zones 4,5,6 9 = All zones 10 = Disabled	0 - 10	0
25.	3.	System Diagnostics				
25.	3.	0	CH Flow Set T		°C	
25.	3.	1	System Flow T		°C	
25.	3.	2	Outdoor T		°C	
25.	3.	3	Storage Temperature - High		°C	
25.	3.	4	Storage Temperature - Low		°C	
25.	3.	5	System Pump Status			
25.	3.	6	DHW Pump Status			
25.	4.	Cascade Diagnostics				
25.	4.	0	Cascade Power level		%	
25.	4.	1	Total Boilers			
25.	4.	2	Available Boilers			
25.	4.	3	Active Boilers			
25.	4.	4	Cascade Status			
25.	5.	Error History				
25.	5.	0	Last 10 Errors			
25.	5.	1	Reset Error List			
			Reset? OK=Yes,esc=No			
25.	6.	Reset Menu				
25.	6.	0	Reset Factory Settings			
			Reset? OK=Yes,esc=No			
25.	7.	Other				
25.	7.	0	System DHW recirculation target		10- 90 °C	50
25.	7.	1	Thermal cleanse start time	Starting time for the thermal cleanse cycle	00:00 - 23:45	01: 00
25.	7.	2	Thermal cleanse cycle frequency		24 - 480 hour	168
25.	7..	7	Negative Gain Multiplier cascade	Change the speed of the heat Load when T10 > than setpoint	1 - 25	1

Operation

Parameter listing

Menu	Submenu	Parameter	Name	Description	Range	Factory settings
26..32.	Commercial Boiler Slave 1..					
26..32.	0	General				
26..32.	0.	0	Engines Number			
26..32.	0.	1	Gas type	0 = NG, 1 = LPG	0 - 1	0
26..32.	0.	2	Maximum Water temp		20 - 95 °C	90
26..32.	0.	3	Max CH Adjustable		0 - 100 %	100
26..32.	0.	5	Altitude		0 - 1000 m	0
26..32.	0.	6	Boiler tank solar integration	0 = Absent 1 = Present	0 - 1	0
26..32.	0.	7	Emergency setpoint		20 - 90 °C	45
26..32.	0.	8	Max DHW adjustable		0-100 %	100
26..32.	0.	9	Boiler model	0 = Undefined 1 = 60kW 2 = 70/75kw 3 = 100/105kw 4 = 120/125kW 5 = 140/150kW 6 = 170/180kW 7 = 200/210kW	Depending on boiler type	Also Depending on boiler type
26..32.	3.	Water Circulation				
26..32.	3.	0	Max PWM Pump		46 - 95 %	95
26..32.	3.	1	Min PWM Pump		40 - 95 %	46
26..32.	3.	2	CH pump overrun		0 - 16 min.	5
26..32.	3.	3	Max pressure		2.0 - 6.0 bar	6.0
26..32.	3.	5	Delta T pump control		20 - 25°C	20
26..32.	5.	Domestic Hot Water				
26..32.	5.	0	DHW Setpoint Temperature		40 - 65°C	65
26..32.	5.	1	Comfort Function	0 = Disabled 1 = Time Based 2 = Always Active	0 - 2	0
26..32.	5.	3	Boiler DHW Mode	0 = CH Only 1 = DHW Tank NTC 2 = DHW Tank Thermostat	0 - 2	0
26..32.	5.	4	Anti-legionella Function	0 = OFF 1 = ON	0 - 1	0
26..32.	5.	5	Boiler DHW Charging Type	0 = Recharging 1 = Full charging 2 = Full charging Legio	0 - 2	0
26..32.	5.	7	Boiler DHW Circulating Pump Release	0 = Release 1 = Time Programs 2 = Circ Pump special Time Programs	0 - 2	0

Operation

Parameter listing

Menu	Submenu	Parameter	Name	Description	Range	Factory settings	
26..32.	6.	Configurable Input- Output					
26..32.	6.	0	MTS 1 input	0 = None 1 = Common flow sensor (T10) 2 = DHW storage tank bottom 3 = DHW re-circulating sensor 4 = DHW charging sensor do not use 5 = Buffer storage tank top 6 = Buffer storage tank bottom 7 = Flue gas temp sensor/thermostat	0 - 7	0	
26..32.	6.	1	MTS 2 input	0 = None 1 = Common flow sensor (T10) 2 = DHW storage tank bottom 3 = DHW re-circulating sensor 4 = DHW charging sensor do not use 5 = Buffer storage tank top 6 = Buffer storage tank bottom 7 = Flue gas temp sensor/thermostat	0 - 7	0	
26..32.	6.	2	MTS 3 input	0 = None 1 = Common flow sensor (T10) 2 = DHW storage tank bottom 3 = DHW re-circulating sensor 4 = DHW charging sensor do not use 5 = Buffer storage tank top 6 = Buffer storage tank bottom 7 = Flue gas temp sensor/thermostat	0 - 7	0	
26..32.	6.	4	PADIN 1 input	0 = None 1 = Room thermostat HC1 ON/OFF/ Room thermostat HC4 ON/OFF when second Zone module clip-in 3 is applied 2 = Room thermostat HC2 ON/OFF/ Room thermostat HC5 ON/OFF when second Zone module clip-in 3 is applied 3 = Room thermostat HC3 ON/OFF/ Room thermostat HC6 ON/OFF when second Zone module clip-in 3 is applied 4 = 0- 10V input request (BMS) 5 = DHW time input 6 = Heat generator lock only applies on the boiler (not complete cascade) 7 = Gas Pressure Switch - only applies on the boiler (not complete cascade) 8 = CH timer input	0 - 8	0	

Operation

Parameter listing

Menu	Submenu	Parameter	Name	Description	Range	Factory settings
26..32.	6.	5	PADIN 2 input	0 = None 1 = Room thermostat HC1 ON/OFF/ Room thermostat HC4 ON/OFF when second Zone module clip-in 3 is applied 2 = Room thermostat HC2 ON/OFF/ Room thermostat HC5 ON/OFF when second Zone module clip-in 3 is applied 3 = Room thermostat HC3 ON/OFF/ Room thermostat HC6 ON/OFF when second Zone module clip-in 3 is applied 4 = 0- 10V input request (BMS) 5 = DHW time input 6 = Heat generator lock only applies on the boiler (not complete cascade) 7 = Gas Pressure Switch - only applies on the boiler (not complete cascade) 8 = CH timer input	0 - 8	0
26..32.	6.	6	PADIN 3 input	0 = None 1 = Room thermostat HC1 ON/OFF/ Room thermostat HC4 ON/OFF when second Zone module clip-in 3 is applied 2 = Room thermostat HC2 ON/OFF/ Room thermostat HC5 ON/OFF when second Zone module clip-in 3 is applied 3 = Room thermostat HC3 ON/OFF/ Room thermostat HC6 ON/OFF when second Zone module clip-in 3 is applied 4 = 0- 10V input request (BMS) 5 = DHW time input 6 = Heat generator lock only applies on the boiler (not complete cascade) 7 = Gas Pressure Switch - only applies on the boiler (not complete cascade) 8 = CH timer input	0 - 8	0
26..32.	6.	7	Boiler Lock	Boiler lock. When applied on Cascade master complete cascade will be blocked.	11 - 11	11
26..32.	7.	Configurable Input- Output 2				
26..32.	7.	0	MO1 output HV 230Vac	0 = None 1 = System pump (25.1.6) 2 = HC1 Pump 3 = DHW re-circulating pump 4 = DHW charging pump 5 = BUF filling pump 6 = Storage tank transfer pump	0-6	0
26..32.	7.	1	VFR 1 output 1	0 = None 1 = System pump (25.1.6) 2 = HC1 Pump 3 = DHW re-circulating pump 4 = DHW charging pump 5 = BUF filling pump 6 = Storage tank transfer pump 7 = Heat generation shut off valve 8 = Heat request 9 = Alarm output 10 = LPG/ Room Supply Fan	0-10	0

Operation

Parameter listing

Menu	Submenu	Parameter	Name	Description	Range	Factory settings	
26..32.	7.	2	VFR 2	0 = None 1 = Heat generation shut off valve 2 = Heat request 3 = Alarm output 4 = LPG/ Room Supply Fan	0-4	0	
26..32.	7.	3	VFR 3	0 = None 1 = Heat generation shut off valve 2 = Heat request 3 = Alarm output 4 = LPG/ Room Supply Fan	0-4	0	
26..32.	7.	4	MO1 output PWM or 0-10V for BMS	0-10 Volt feedback active only inverted	5-5	5	
26..32.	7.	5	MO2 output PWM or 0-10V for BMS	0-10 Volt feedback active only inverted	5-5	5	
26..32.	8	Boiler manual settings					
26..32.	8.	0	Manual mode activation	0 = OFF 1 = ON	0 - 1	0	
26..32.	8.	1	Boiler pump control	0 = OFF 1 = ON	0 - 1	0	
26..32.	8.	2	Fan control	0 = OFF 1 = ON	0 - 1	0	
26..32.	8.	3	Boiler pump control 2nd Engine	0 = OFF 1 = ON	0 - 1	0	
26..32.	8.	4	Fan control 2nd Engine	0 = OFF 1 = ON	0 - 1	0	
26..32.	8.	5	Diverter valve control	0 = OFF 1 = ON	0 - 1	0	
26..32.	8.	6	Multi-Functional Output 1	0 = OFF 1 = ON	0 - 1	0	
26..32.	8.	7	Free Contacts 1,2,3	0 = OFF 1 = ON	0 - 1	0	
26..32.	9	Test & Utilities					
26..32.	9.	0	Test mode	0 = OFF 1 = ON	0 - 1	0	
26..32.	9.	1	Air-purge function	0 = OFF 1 = ON	0 - 1	0	

Operation

Parameter listing

Menu	Submenu	Parameter	Name	Description	Range	Factory settings
26..32.	9.	2	Force Backup			
			0 = OFF 1 = ON		0 - 1	0
26..32.	9.	3	Force Restore			
			0 = OFF 1 = ON		0 - 1	0
26..32.	10	Engine 1 diagnostics				
26..32.	10.	0	Fan Speed		rpm	
26..32.	10.	1	Pump Modulation %		%	
26..32.	10.	2	Ionization current		uA	
26..32.	10.	3	SAFETY Flame sensor			
26..32.	10.	4	CH flow temperature		°C	
26..32.	10.	5	CH Flow T 2A		°C	
26..32.	10.	6	CH Return T		°C	
26..32.	10.	7	Pump Flow Rate		l/min	
26..32.	10.	8	Gas Power		kW	
26..32.	11	Engine 2 diagnostics				
26..32.	11.	0	Fan Speed		rpm	
26..32.	11.	1	Pump Modulation %		%	
26..32.	11.	2	Ionization current		uA	
26..32.	11.	3	SAFETY Flame presence			
26..32.	11.	4	CH Flow T		°C	
26..32.	11.	5	CH Flow T 2A		°C	
26..32.	11.	6	CH Return T		°C	
26..32.	11.	7	Pump Flow Rate		l/min	
26..32.	11.	8	Gas Power		kW	
26..32.	12	Boiler Diagnostics				
26..32.	12.	0	Flue Gas T		°C	
26..32.	12.	1	Diverter Valve Pos			
			Hot Water Central Heating			
26..32.	12.	2	Heating Circuit Pressure		bar	
26..32.	12.	3	Boiler Power level		%	
26..32.	12.	4	Storage Temperature - High		°C	
26..32.	12.	5	Storage Temperature - Low		°C	
26..32.	12.	6	Boiler Status			

Operation

Parameter listing

Menu	Submenu	Parameter	Name	Description	Range	Factory settings
26..32.	14	Engine 1 Statistics				
26..32.	14.	0	Number Of Ignition Cycles (n x10)			
26..32.	14.	1	Hours Burner On (h x10)			
26..32.	14.	2	Boiler circulator cycles No. (n /10)			
26..32.	14.	3	Time of circulator on (h x 10)			
26..32.	14.	4	Fan cycles No. (n x10)			
26..32.	14.	5	Time of fan ON (h x 10)			
26..32.	14.	6	Number Of Flame Faults (n x10)			
26..32.	15	Engine 2 Statistics				
26..32.	15.	0	Number Of Ignition Cycles (n x10)			
26..32.	15.	1	Hours Burner On (h x10)			
26..32.	15.	2	Number of boiler circulator cycles (n x10)			
26..32.	15.	3	Time of circulator on (h x 10)			
26..32.	15.	4	Number of fan cycles (n x10)			
26..32.	15.	5	Time of fan ON (h x 10)			
26..32.	15.	6	Number Of Flame Faults (n x10)			
26..32.	16	Boiler Statistics				
26..32.	16.	0	Life Time (h x 10)			
26..32.	16.	1	Hours Burner On CH (h x10)			
26..32.	16.	2	Hours Burner On DHW (h x10)			
26..32.	16.	3	Diverter valve cycles No. (n /10)			
26..32.	16.	4	Heat Req Duration (h x 10)		min	
26..32.	17	Service				
26..32.	17.	0	Months to Next Maintenance		0 - 60	12
26..32.	17.	1	Mainten On Days Act 0 = OFF 1 = ON		0 - 1	0
26..32.	17.	2	Maint Warn Reset Reset? OK=Yes,esc=No			
26..32.	17.	3	SW Version Interface			
26..32.	17.	4	SW Version Main			
26..32.	17.	5	SW Version BHE2			
26..32.	18	Error History				
26..32.	18.	0	Last 10 Errors			
26..32.	18.	1	Reset Error List Reset? OK=Yes,esc=No			
26..32.	19	Reset Menu				
26..32.	19.	0	Reset Factory Settings Reset? OK=Yes,esc=No			
26..32.	20	Other				
26..32.	20.	0	DHW modulation setpoint		°C	

Operation

Parameter listing

Menu	Submenu	Parameter	Name	Description	Range	Factory settings
26..32.	21	Other 2				
26..32.	21.	8	Negative Gain Multiplier	Change the speed of the heat Load when T10 > than setpoint	1 - 25	1
42	Building Management System					
42.	0	General				
42.	0.	0	BMS Control Mode			
			0 = Disabled 1 = Voltage Power 2 = Voltage Temp 3 = Current Power 4 = Current Temp 5 = External Controller Power 6 = External Controller Temp		0 - 6	0
42.	0.	1	BMS Max Temp		°C	90
42.	0.	1	BMS Min Temp		°C	20
42.	1	Analog Level Settings				
42.	1.	0	BMS Analog Control Voltage to Started Heat Demand		V	1
42.	1.	1	BMS Analog Control Voltage to Stop Heat Demand		V	0,5
42.	1.	2	BMS Analog Control Voltage for Maximum Heat Demand		V	9,5
42.	1.	3	BMS Analog Control Voltage for Minimum Heat Demand		V	2
42.	1.	4	BMS Analog Control Current to Start Heat Demand		mA	60
42.	1.	5	BMS Analog Control Current to Stop Heat Demand		mA	50
42.	1.	6	BMS Analog Control Current for Maximum Heat Demand		mA	190
42.	1.	7	BMS Analog Control Current for Minimum Heat Demand		mA	70
42.	2	Diagnostics				
42.	2.	0	BMS Status			
			0 = Absent 1 = Disabled 2 = OFF 3 = Standby 4 = Heat Request 5 = Config Error		0 - 5	
42.	2.	1	BMS Level		%	
42.	2.	2	BMS SetPoint		°C	
42.	2.	3	BMS Input Voltage		V	
42.	2.	4	BMS Input Current		mA	

Operation

Detail parameter description

Date and time

DHW preheating

Date and time

The control unit is equipped with a 365-day clock that displays day, month, year and time. To ensure correct boiler operation when using time programs, the date and time must be set correctly. If the boiler is connected to the App via Wifi, the Internet time is automatically taken over.

Hot water preheating function (comfort function)

This parameter allows the end user to select the hot water comfort. The higher the comfort, the higher the energy consumption.

- OFF: The boiler starts to heat the hot water only in the case of a tap
- TIME: after each tapping, the boiler maintains the comfort temperature for 30 minutes
- ON: Boiler keeps hot water 365 / 24h at the desired comfort temperature.

Time program Comfort function DHW

Five different pre-defined time programs are available for DHW heating. These programmes are

activated when DHW preheating is set to "TIME". The programs control the DHW set point for the various switching times. Outside these time windows, hot water preheating is deactivated.

0-24h	Mo-So	00:00 – 24:00		
P1 Family program	Mo-Do	06:00 – 22:00		
	Fr-Sa	06:00 – 23:00		
	So	07:00 – 22:00		
P2 Program without noon	Mo-Do	06:00 – 08:00	16:00 – 22:00	
	Fr	06:00 – 08:00	15:00 – 23:00	
	Sa	07:00 – 23:00		
	So	08:00 – 22:00		
P3 Program with lunch	Mo-Do	06:00 – 08:00	11:30 – 13:00	16:00 – 22:00
	Fr	06:00 – 08:00	11:30 – 23:00	
	Sa	06:00 – 23:00		
	So	07:00 – 22:00		
6-22h	Mo-Do	06:00 – 22:00		

Operation

Function Thermoregulation Room temperature day / night

Function Thermoregulation

see Complete Menu activation of automatic heating temperature control (AUTO function). This function allows the heating operation to be adapted to external environmental conditions and to the type of system in which it is installed.

This allows to easily achieve high comfort without unnecessary waste of money, energy and efficiency and helps to significantly reduce the wear of the components.

Contact a qualified technician to inform you about the device and then program the system to meet your needs.

Thermoregulation OFF:

The boiler operates and provides a constant flow temperature. The burner modulates according to system load. This is achieved by monitoring the system return temperature.

Thermoregulation ON:

One outdoor sensor and/or a room sensor (accessories) detect changes the outside or room temperature. The controller calculates the correct flow temperature in order to achieve the desired room temperature level (e.g. 21 °C) to hold. This allows highest Comfort and energy saving.

If a room thermostat or Room sensor (accessory) used the boiler switches in both cases (ON/OFF) according to the current Room temperature on / off.

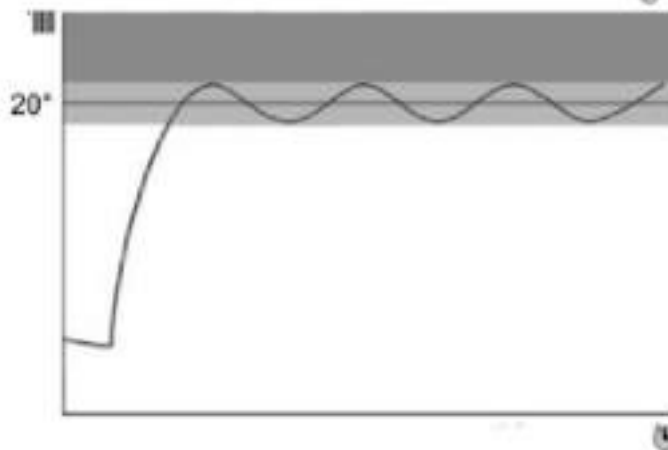
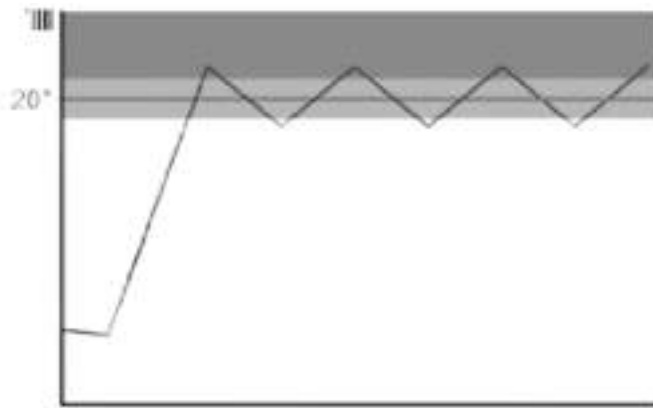

Room temperature day / night

The room temperatures (all zones 1-3) can be set to different setpoints. These setpoints become effective with the selected operating mode and the time program, so that different temperature levels can occur in each zone.

The bandwidth of the adjustable target values is limited by their interdependence, which can be seen in the accompanying graphic. Day setpoint (comfort), factory setting 21 °C
Night setpoint (reduced), factory setting 16 °C

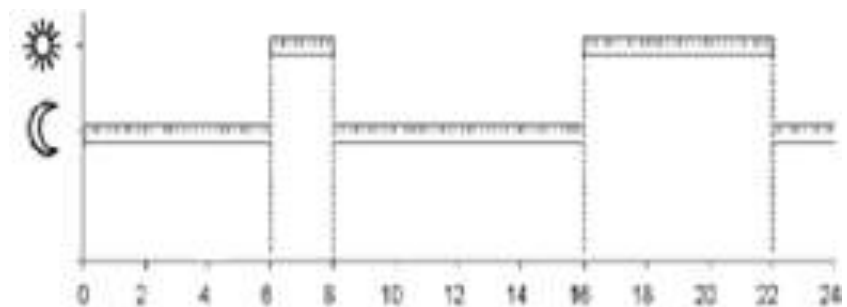

Operation

Time programs Heating Heating curve Slope Heating curve Parallel shift

Time programs Heating

The end user can choose from five pre-defined time programs for heating systems according to his wishes. If a time programme is activated, the boiler operates in the desired periods in order to keep the room temperature at the comfort temperature level. Outside these periods, the boiler operates at a reduced temperature level.

Alternatively, you can create your own time programmes or adapt existing programmes to your own requirements.

Heating curve Slope

The flow temperature set-point is adjusted according to the measured outside air temperature and the set weather compensation curve.

Example: Weather compensation curve 3.5 will provide a higher primary flow temperature set-point at a given outside air temperature than curve 1.0. The weather compensation curve can be adjusted to suit the heat loss characteristic of specific buildings.

Increase setting: Increases the flow temperature, especially when the outdoor temperature is cold.
Lower the setting: Reduces the flow temperature, especially when the outdoor temperature is cold.

Heating curve Parallel shift

If the ambient temperature is too hot or too cold regardless of the outdoor temperature, use the parallel shift to adjust the curve.

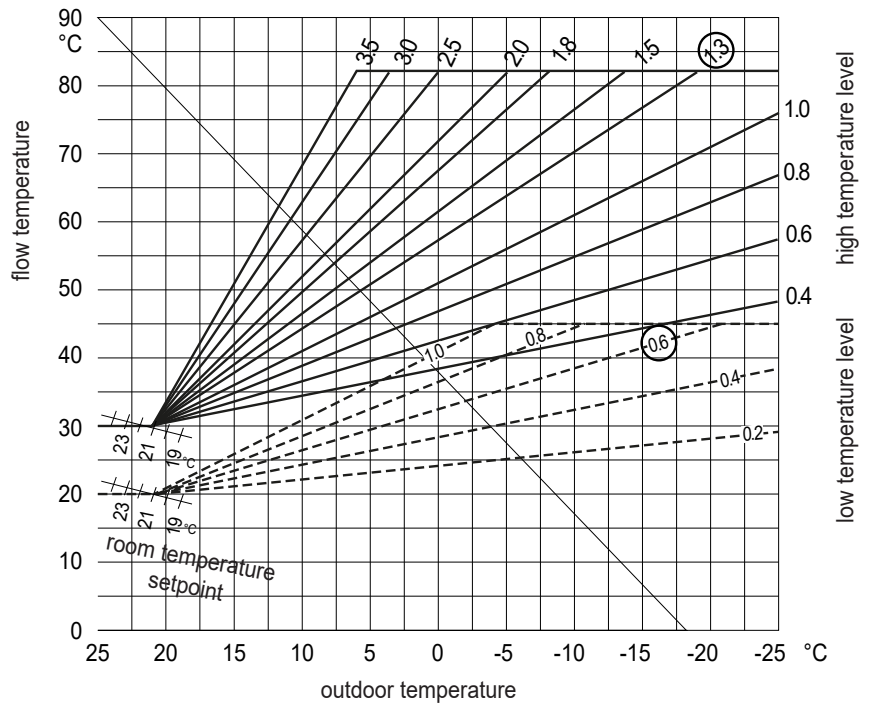

Depending on the system conditions (boiler settings during installation), a setting range of $\pm 7\text{K}$ (at low temperature) or $\pm 14\text{K}$ (at high temperature) is possible.

0-24h	Mo-So	00:00 – 24:00		
P1 Family program	Mo-Do	06:00 – 22:00		
	Fr-Sa	06:00 – 23:00		
	So	07:00 – 22:00		
P2 Program without noon	Mo-Do	06:00 – 08:00	16:00 – 22:00	
	Fr	06:00 – 08:00	15:00 – 23:00	
	Sa	07:00 – 23:00		
	So	08:00 – 22:00		
P3 Program with lunch	Mo-Do	06:00 – 08:00	11:30 – 13:00	16:00 – 22:00
	Fr	06:00 – 08:00	11:30 – 23:00	
	Sa	06:00 – 23:00		
	So	07:00 – 22:00		
6-22h	Mo-Do	06:00 – 22:00		



Automatic summer / winter changeover

Automatic summer / winter changeover

If this function is activated, the boiler automatically changes from “winter” mode ( + ) to “summer” mode (), based on outdoor temperature conditions.

This means that the boiler can automatically activate or deactivate the heating mode. The criteria for the change are as follows:

If the outdoor temperature during 5h (delay time) is more than 1K above the desired summer / winter changeover temperature, the boiler switches from winter to summer mode.

If the outdoor temperature during 5h (delay time) is more than 1K below the desired summer / winter switching temperature, the boiler switches from winter to summer mode, boiler switches from the summer mode to the winter mode.

Summer/winter change-over temperature

Criterion external temperature in order to be able to winter operation in summer operation to change, factory setting is 20°C.

Hint:

The automatic summer / winter switchover can only be used if an outdoor sensor is installed.

Commissioning

Change the language on the screen

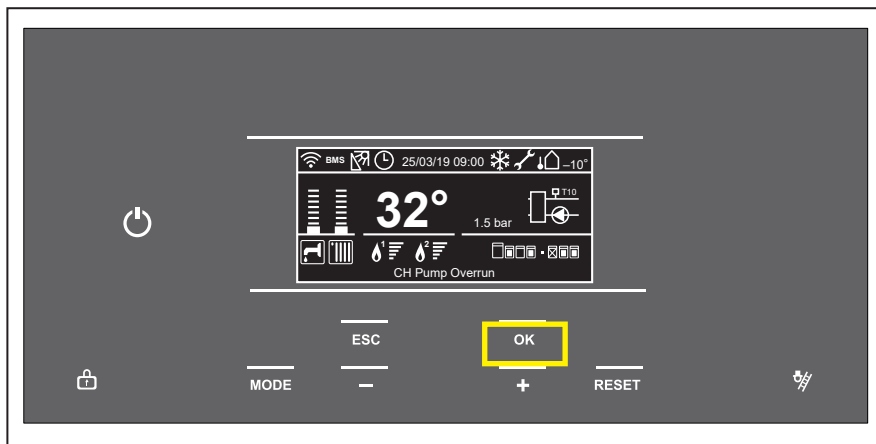

1 From the controller Home screen, press **OK**.



2 The **“+”** and **“–”** buttons are used to select the parameter set and make adjustments to individual parameter settings. The **OK** button selects the parameter set and confirms and stores any adjustments made.

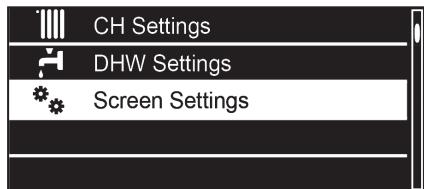

3 Use **“+”** to go down and **“–”** to go up to highlight **Screen Settings**. Press **OK**.

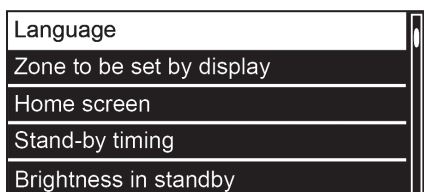

4 Option **Language** is highlighted. Press **OK**.

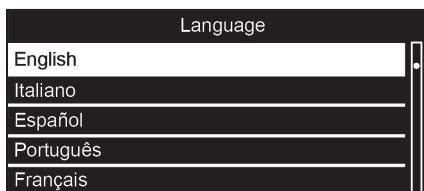

5 Use **“+”** to go down and **“–”** to go up to highlight the desired language. Press **OK**.

The language is changed now.

Commissioning

Change the time and date

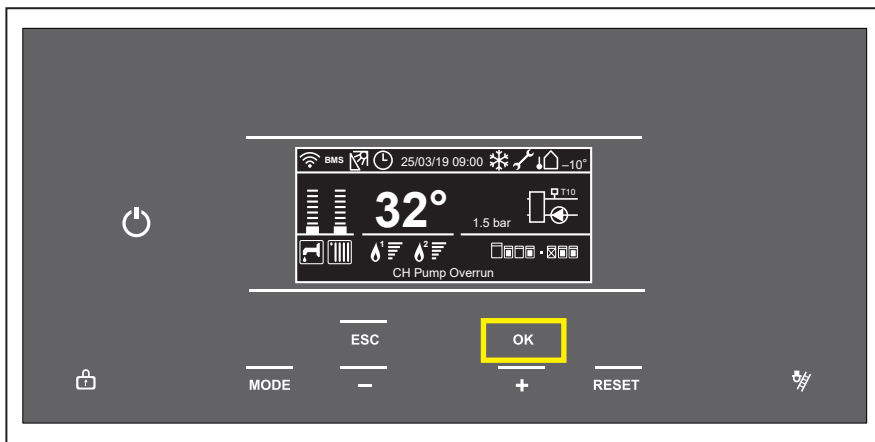

Attention:
in case of the boiler is connected to Wifi, the date and time are actualised automatically.

1 From the controller Home screen, press **OK**.



2 Use **“+”** to go down and **“-”** to go up to highlight **Complete Menu**. Press **OK**.

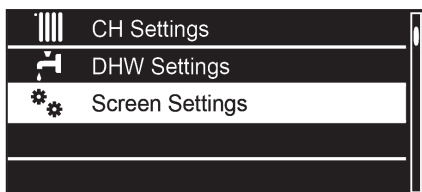

3 Use **“+”** to go down and **“-”** to go up to highlight **Screen Settings**. Press **OK**.



4 Use **“+”** to go down and **“-”** to go up to highlight **Time & Date**. Press **OK**.



5 Use **“+”** to go down and **“-”** to go up to highlight the desired field. Press **OK**. The relevant field starts to flash. Use **“+”** to go down and **“-”** to go up to highlight the correct value. Press **OK**. After correctly filled in all fields, Press **Save**.

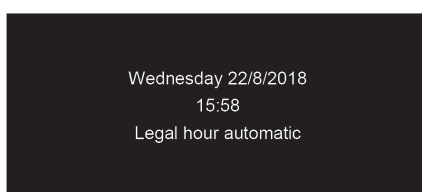

The message in the screen left appears.

The settings are saved.

Commissioning

Parameter adaption to the heating system

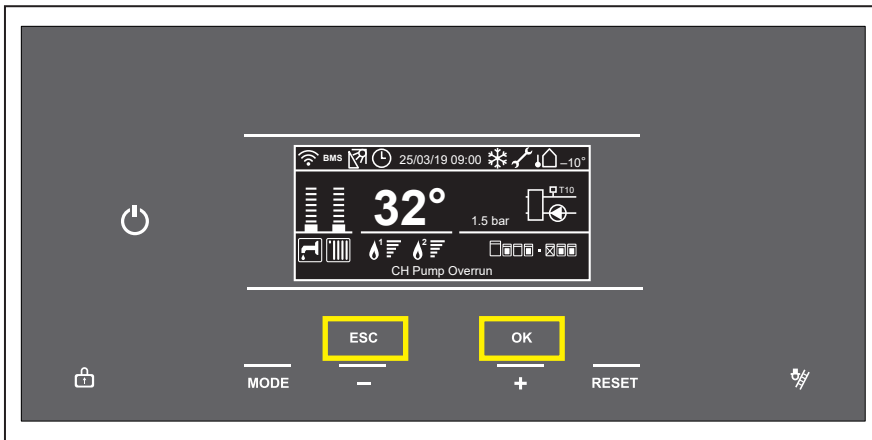

The settings are accessible through a code.

- 1 From the controller Home screen, press the **ESC** and **OK** buttons at the same time for 7 seconds.



- 2 Use “+” to go down and “-” to go up to highlight **007** as the Technical Code. Press **OK**.

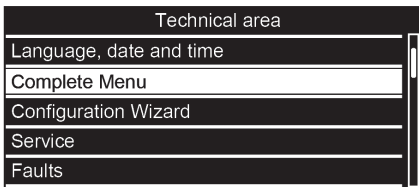

- 3 Use “+” to go down and “-” to go up to highlight **Complete Menu**. Press **OK**. It is now loading the menu.

Commissioning

Parameter adaption to the heating system

Parameter	Name	Description	Factory settings	Fix Flow T	Basic thermoregulation	Room T Only	Outdoor T Only	Room + Outdoor T
4	Zone 1 Parameters							
4.1	Automatic winter mode							
4.1.0	Automatic winter mode activation	O = OFF - - - 1 = ON	0	**	**	**	**	**
4.1.1	Automatic winter mode threshold	outside temperature	20°C	**	**	**	**	**
4.1.2	Automatic winter mode delay time	adjustable time for the treshold	60 min.	**	**	**	**	**
4.2	Zone 1 Settings							
4.2.0	Zone temperature range	0 = Low Temp (LT) 1 = High Temp (HT)	1	*	*	*	*	*
4.2.1	Thermoregulation	0 = Fix Flow T 1 = Basic thermoregulation 2 = Room T Only 3 = Outdoor T Only 4 = Room + Outdoor T	0	0	1	2	3	4
4.2.2	Slope	LT: From 0.2 - 1.0 HT: From 0.4 - 3.5	0.6LT 1.3HT	*	*	*	*	*
4.2.3	Offset	LT: From -7°C to +7°C HT: From -14°C to +14°C	0 0	*	*	*	*	*
4.2.5	Max T	LT: From 10°C to 45°C HT: From 10°C to 90°C	LT 45 HT 85	*	*	*	*	*
4.2.6	Min T	LT: From 10°C to 45°C HT: From 10°C to 90°C	LT 20 HT 40	*	*	*	*	*
4.2.8	Quick night setback	0 = OFF / 1 = ON	0	*	*	*	*	*
4.2.9	Heat request mode	0 = Standard 1 = RT Time Programs Exclusion 2 = Forcing Heat Demand	0	**	**	**	**	**
4.3	Zone 1 Diagnostics							
4.3.0	Room T	°C						
4.3.1	Room T setpoint	°C						
4.3.2	Flow temperature	°C						
4.3.3	Return temperature	°C						
4.3.4	Heat request Z1	0 = OFF, 1 = ON						
4.3.5	Pump status	0 = OFF, 1 = ON						
4.3.9	Heating rate							

Value = mandatory setting

* adapt to the design characteristics of the heating system

** adapt to the comfort needs of the customer

Commissioning

Weather compensation Select thermoregulation type

To set the boiler to weather compensation, please set parameter 4.2.1 to 3 with an ON/OFF or eBus controller.

Menu	
0	Network
4	Zone1 Parameters
5	Zone2 Parameters
6	Zone3 Parameters
24	Commercial boiler

4 Zone1 Parameters	
4.0	Setpoint
4.1	S/W Changeover
4.2	Settings
4.3	Diagnostics

4.2 Settings		
4.2.0	Zone temperature range	1
4.2.1	Thermoregulation	0
4.2.2	Slope	1.5
4.2.3	Offset	0
4.2.4	Room Influence Proportional	10

1 Use “+” to go down and “-” to go up to highlight the Parameters Zone you want to set. In this case **Zone 1 Parameters**. Press **OK**.

2 Use “+” to go down and “-” to go up to highlight **4.2 Z1 Settings**. Press **OK**.

3 Use “+” to go down and “-” to go up to highlight **4.2.1 Thermoregulation**. Press **OK**.

4 Make a choice between 5:
0 Fix Flow T

Room thermostat with fixed flow temperature

(T_{start} 58°C)¹⁾, every 16 min ±4 K

¹⁾ = Factory setting at high temperature level

1 Basic Thermoreg

Room thermostat with automatic flow temperature adaptation

2 Room T Only

Pure room temperature control with room sensor

The flow temperature is controlled as a function of the room temperature setpoint, the current room temperature and its current course. A slight increase in the room temperature, for example, immediately reduces the flow temperature.

3 Outdoor T Only

Weather compensated control with outdoor sensor

The flow temperature is calculated via the heating curve as a function of the current outdoor temperature. This type of control requires that the heating characteristic is set correctly, as the control system does not take room temperature into account in this setting.

4 Room + Outdoor T

Weather and room temperature control with outdoor and room sensor

The deviation of the room temperature from the setpoint is recorded and taken into account during temperature control. In this way, any external heat generated can be taken into account and a more constant room temperature becomes possible.

The influence of the deviation is set proportionally. The better the reference room is (unaltered room temperature, correct installation location, etc.), the higher the value can be set.

Example:

Approx. 4: Good reference room

Approx. 1: Unfavourable reference room

4.2.1 Thermoregulation	
4	
Room+Outdoor T	
Maximum value	4
Minimum value	0

Commissioning

Inspection

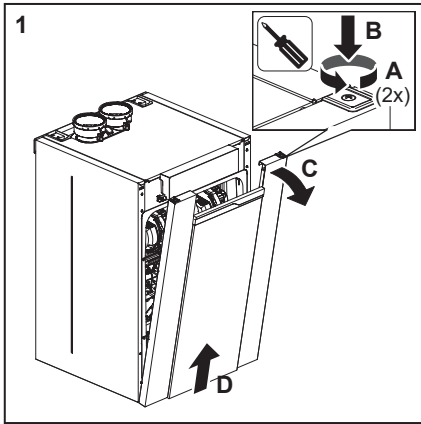

Caution:

After panelling removal, 230V parts can be reached. Boiler inspection is only to be carried out by qualified staff.

Removal of frontal panelling

The front panelling must first be removed, to be able to carry out maintenance on the boiler.

1. Unscrew the 2 screws of quick-locks on top of frontal panel (A). Push the quick locks (B) and remove the frontal panel (C), (D) (= air box).

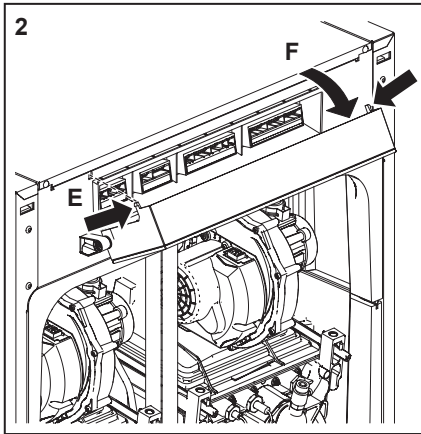

Removal of top panelling

Top panelling must be removed to be able to reach the burner control unit.

2. Press both external sides of the control unit HMI (E) and rotate the display (F).
3. Pull the top panelling in a forward motion (G), (H).

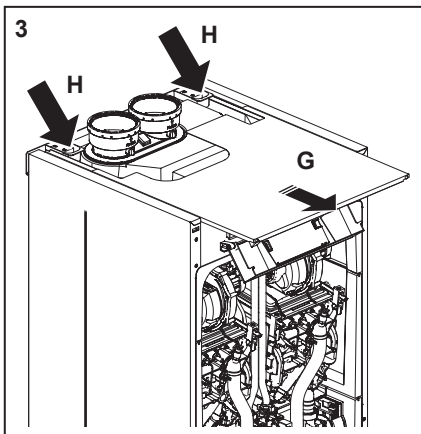

The panelling of the equipment consists of metal and plastic parts, which can be cleaned with a mild (non-aggressive) cleaning agent.

When carrying out maintenance works, only original Rendamac replacement parts may be used.

Checks prior to commissioning

Changing settings such as burner pressure and setting the amount of air is not necessary.

Only in the case of failures or replacement of the gas unit, venturi and/or ventilator, does one have to check and adjust the O₂ / CO₂ percentage accordingly.

Following maintenance tasks always check all gas-conducting components on leakages by use of leakage detection fluid (LDF).

Commissioning

Flue gas analysis Full load (Step 1/3)

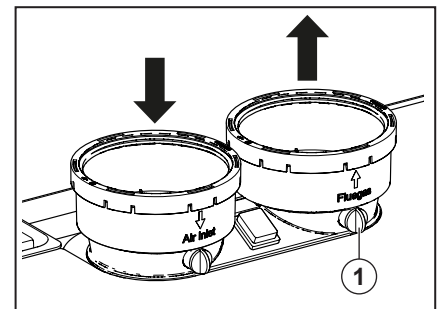
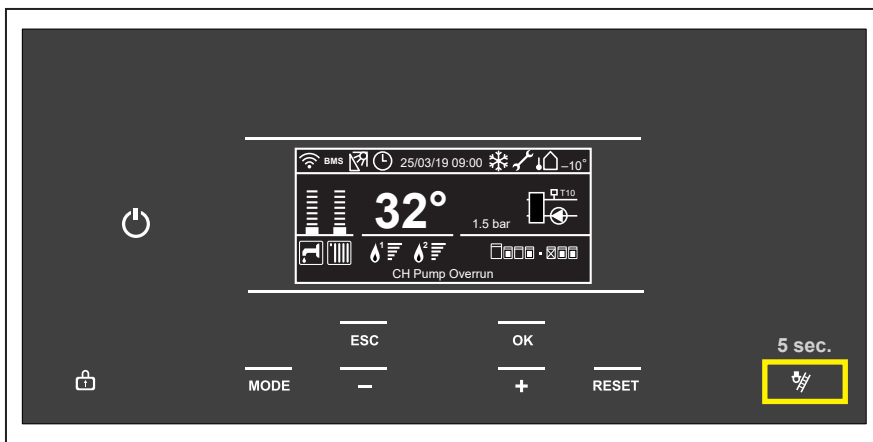

Legend

1. Measuring point for the flue gas probe.

The O₂ / CO₂ check consists of 2 steps or, if necessary, 3 steps:

- Step 1: Check on full load**
Step 2: Check on low load
Step 3: Adjustment (if necessary).

Step 1: O₂ / CO₂ check on full load
 The O₂ or CO₂ setting is preset at the factory to E, namely natural gas, for all equipment units. A calibrated O₂ or CO₂ control measurement must be carried out during commissioning.

- Ensure that the boiler is in operation and that the heat, which it produces, can be discharged.

Set the load of each engine

- Press the chimney sweep button for 5 seconds;
- Select with “+” or “-” burner 1 or 2 (in case it is present). Press OK;
- The boiler will switch to CH power shown on the screen.

The modulation rate can now be adjusted between minimum 0% and maximum 100%.

- Press the “+” button until you reach 100%;
- Press **OK**;
 The selected engine will switch to max power output, the screen shows 100% (heating capacity).
- Calibrate the Flue Gas Analyser, and then insert the flue gas probe of the Flue Gas Analyser into the measuring point of the flue gas pipe “1” (see illustration);
- Wait for one minute and then carry out a combustion analysis;
- Check whether the O₂/CO₂ values that are listed below correspond to the measured value.

After this check has been done, once more test the O₂/CO₂ value at low load (see Step 2 on page 84). If there are any deviations in the result, then these must be corrected (see Step 3 on page 85).

Set the load of complete boiler

- Press the chimney sweep button for 5 seconds;
- Select with “+” or “-” burner 1+2

The Chimney Power Level is now Settable (with “+” and “-” buttons) between the minimum Power and the maximum Power of the complete boiler.

Diagnosics

During chimney sweep function it is possible to go to the diagnosics by means of

- 1 Press the ESC and OK buttons at the same time for 7 seconds.
- 2 Use “+” to go down and “-” to go up to highlight **007 as the Technical Code. Press OK.**
- 3 Use “+” to go down and “-” to go further

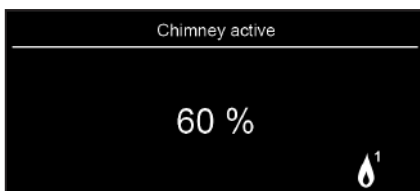

O ₂ / CO ₂ check on full load (Step 1)		
Full load	Natural gas (G20)	Propane (G31)*
O ₂	Nominal 4,8%	Nominal 5,0%
	Minimum 4,1%, maximum 5,6%	Minimum 4,5%, maximum 5,4%
CO ₂	Nominal 9,0%	Nominal 10,5%
	Minimum 8,6%, maximum 9,4%	Minimum 10,2%, maximum 10,8%

Values are valid with closed cover/air box.

*only possible if LPG conversion kit is installed

Commissioning

Flue gas analysis Low load (Step 2/3)

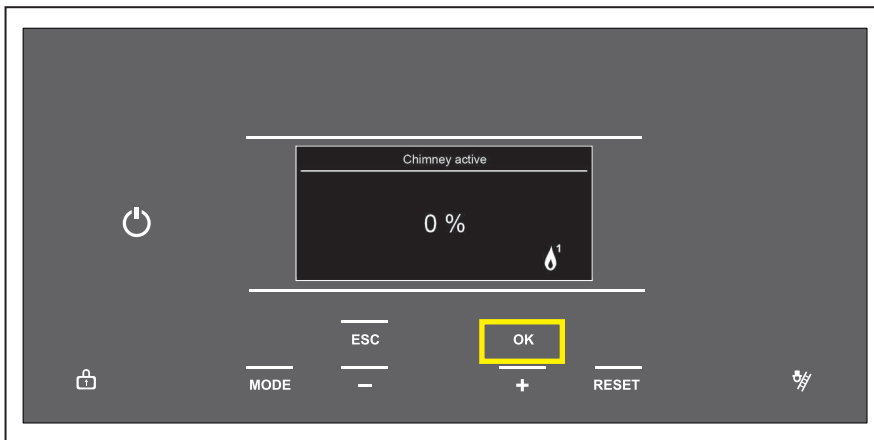

Step 2: O₂ / CO₂ check on low load

Setting the low load

The low load of each engine or of the complete boiler can be set by you as follows:

- Press the “-” button until you reach 0%;
- Press **OK**;
The boiler will switch to minimum power output (low load) of the boiler; the screen shows 0% (heating capacity).

The O₂ value at low load must lie higher than the O₂ value at full load. The measuring procedure must be carried out, until a constant measuring result is achieved. Please contact Rendamac, if the values should lie outside of the applicable tolerances.

End of measuring:

- Press the back button for 5 seconds to exit chimney sweep mode.

This completes the procedure.

The maximum duration of the commissioning function, without interruption, is 20 minutes.

O ₂ / CO ₂ check on low load (Step 2)		
Low load	Natural gas (G20)	Propane (G31)*
O ₂	Minimal 0,5% higher than measured on full load	Minimal 0,2% higher than measured on full load
	Maximum 6,3%	Maximum 6,5%
CO ₂	Minimal 0,3% lower than measured on full load	Minimal 0,1% lower than measured on full load
	Minimum 8,2%	Minimum 9,5%

Values are valid with closed cover/air box.

*only possible if LPG conversion kit is installed

Commissioning

Flue gas analysis

Adjustment on the gas valve (Step 3/3)

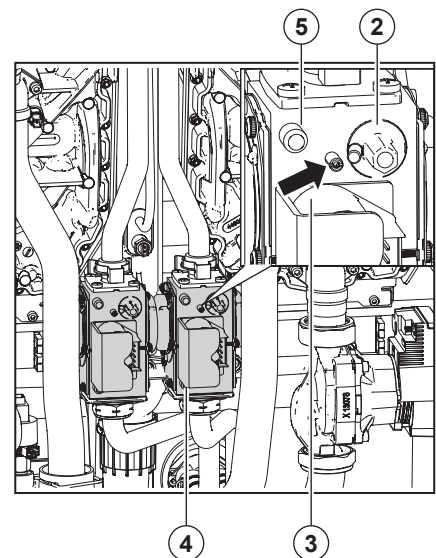
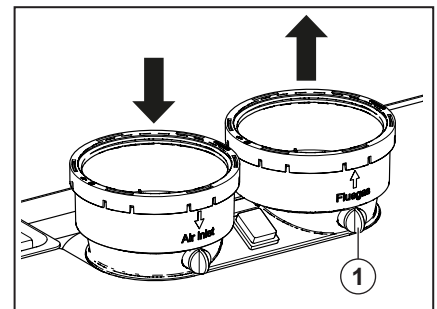
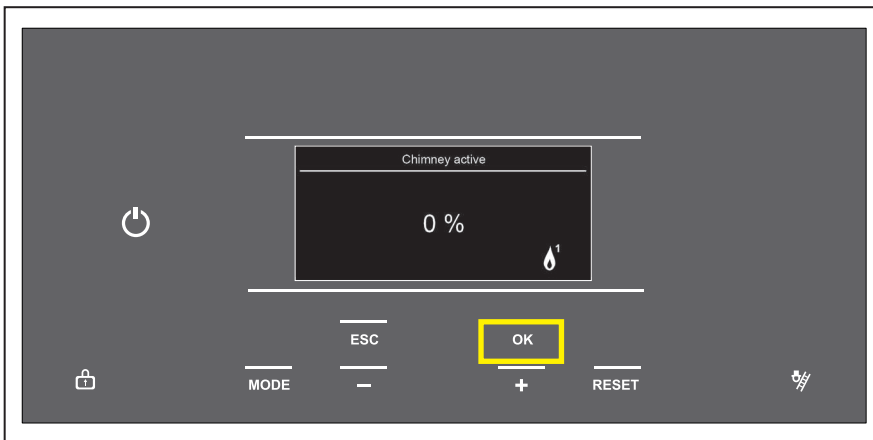

Step 3: Adjustment on the gas valve

Adjust the gas valve only in case the measured values lies out of range of the values mentioned in the table on previous page.

- Open the boiler as described on page 85;
- First put engine 1 on full load (see Step 1) and follow next steps;
- The O_2/CO_2 values are set by using an Allen key (2 mm), or a large flat head screwdriver, on the screw "3". Please observe the following rotating direction;
- Clockwise means more O_2 /less CO_2 ;
- Counterclockwise means less O_2 /more CO_2 ;
- Once done, repeat the steps above for engine 2*.

* Engine change

Press Mode button, menu returns to selection for engine 1 and/or 2.

Legend

1. Measuring point for the flue gas probe
2. Offset regulation
3. Main throttle regulation
4. Pressure P-int
5. Pressure P-out

Attention; close the venturi intake for the non-running engine (bare in mind there is a 3 minute post purge time active).

After this setting has been made, once more test the O_2/CO_2 value at full load and low load. See Step 1 and 2.

Adjustment of the gas valve in case the measured values lies out of range of the values on full load (Step 3)		
Full load	Natural gas (G20)	Propane (G31)*
O_2	4,8%	5,0%
CO_2	9,0%	10,5%

Values are valid with closed cover/air box.

*only possible if LPG conversion kit is installed

Maintenance

Decommissioning and maintenance works Inspection and maintenance interval

Boiler maintenance is only to be carried out by qualified staff with calibrated equipment.

When replacing spare parts only original Rendamac Service parts are to be used. For this purpose, please refer to the Service parts list to find article numbers and exploded views. Please contact Rendamac.

Maintenance intervals

Maintenance has to be carried out at least after 16,000 operational hours max. or every 4 years, whatever comes first. **(To verify with local service depending by installing condition).**

Depending on the intensive use of the device, maintenance intervals will have to be decreased accordingly. For other situations, maintenance intervals may also have to be decreased. In such cases, please contact Rendamac for additional advice.

Inspection and maintenance tasks have to be carried out in accordance with the maintenance instructions at all times. Some tasks are described in these maintenance instructions. For complete inspection and maintenance instructions, see pages 87-93.

When carrying out maintenance on the boiler, the gas tap has to be closed and secured against opening.

Maintenance works

- Use the ON/OFF switch (A) to turn the boiler off;

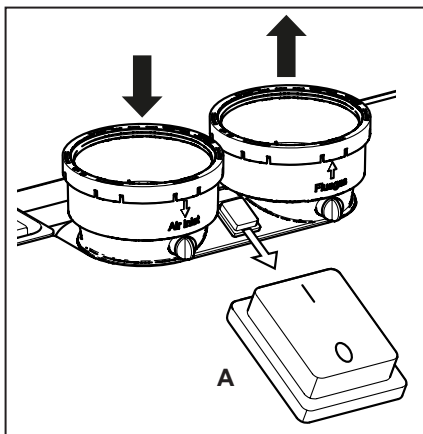

- Interrupt the power supply to the boiler, by operating the mains circuit breaker in the boiler room.
- Interrupt the gas supply to the boiler. During emptying of the boiler, it is possible that a part of the heating water stays behind. Make sure that any remaining heating water cannot freeze, in case of a frost hazard.

Decommissioning

It may be necessary to set the boiler out of service in some situations. Switch the boiler to “off” mode (white color of power button) pressing the power button.

This switches off the functions DHW prog and Pump prog respectively. Rendamac recommends leaving the power switch switched on to ensure that the boiler pump(s) and three-way valve (if fitted) are automatically activated to prevent them from sticking. The frost protection remains active. Leave gas supply open.

If frost, during the period when the boiler is out of operation, is likely, then you are advised to remove the power from the boiler and drain the boiler(s) and installation. In this case: close the gas valve.

Maintenance

Please observe the following safety instructions:

All works on the boiler and the heating facility (assembly, maintenance, repairs) may only be carried out by authorized technicians, by using suitable tools and calibrated measuring instruments. The exchange of components requires original Rendamac replacement parts.

The main stopcock for gas must be closed and secured against reopening.

The casing must first be removed, to be able to carry out maintenance on the boiler. The panel is secured by 2 screws on top of the door. After loosening the screw, the casing can be removed by pulling and lifting it. Follow instruction on page 82.

All equipment is preset at the factory. An O₂ / CO₂ control measurement must be carried out during commissioning.

No change should be made on the zero-point setting. The zero-point setting must only be checked after a malfunction, or after an exchange of the gas valve, the venturi or the ventilator motor.

The zero-point setting does not serve for setting up the combustion-technical characteristic values. These are made exclusively through the O₂ / CO₂ setting.

All gas pipes and screws must be tested for leakproofness, using a leak-detecting spray, whenever maintenance or repair works have been carried out on the boiler.

In this regard, please observe all of the individual maintenance steps documented on page 90 ff., as well as the overview of inspection and maintenance procedures provided on page 92 to 93.

Inspection interval

An inspection must be carried out at least after every 4,000 boiler operating hours, however at least once every year. (To verify with local service depending by installing condition).

An inspection consists of a visual check, of the general condition of the boiler and the installation.

The objectives of an inspection is an assessment of the condition of the equipment, and an evaluation as to when maintenance works are required. A visual inspection can lead to a maintenance procedure.

No tools are required during an inspection (except for tools for removing the panelling). If necessary, the corresponding individual maintenance steps must be carried out, which are listed as of page 93.

Maintenance

Maintenance details

Maintenance interval

An inspection of the burner must be carried out after max. 8,000 operating hours, however at least within 2 years. (To verify with local service depending by installing condition).

Maintenance consists of control and cleaning, or a possible exchange of components of the equipment or installation, which are subject to contamination and wear and tear.

The objective of maintenance is to ensure a long-term functional security and a cost-effective operation of the equipment.

Through a reduction of emissions that are related to the production of heat, primary energy requirements and environment burdening can be substantially reduced.

A visual inspection must always precede the carrying out of maintenance works. In this regard, also see the inspection interval above.

All gas pipes and screws must be tested for leakproofness, after maintenance or repair works have been carried out on the boiler.

Both the gas connection and the pressure on the connection must be checked.

Check at each maintenance intervention the flue gas system on leaks and repair or replace when flue gas leaks are detected.

Maintenance

Maintenance details

CAUTION:

Always interrupt the power supply, before carrying out maintenance or repair works on the boiler. Ventilator unit and burner cassette (see illustration)

- remove the fast clip on the venturi (1) and the gas valve (2) and remove the gasoline (3);
- Replace the gaskets of the gasoline (O-ring) with new ones;
- Disconnect the electrical connections from the fan (4);
- Turn (A) clockwise the left (5) and anti-clockwise the right (6) clamp bars a quarter turn with the hex key and pull these out in a forward Direction (B).
- Now lift the complete fan unit (7) with the upper tray and remove it in a forward motion;

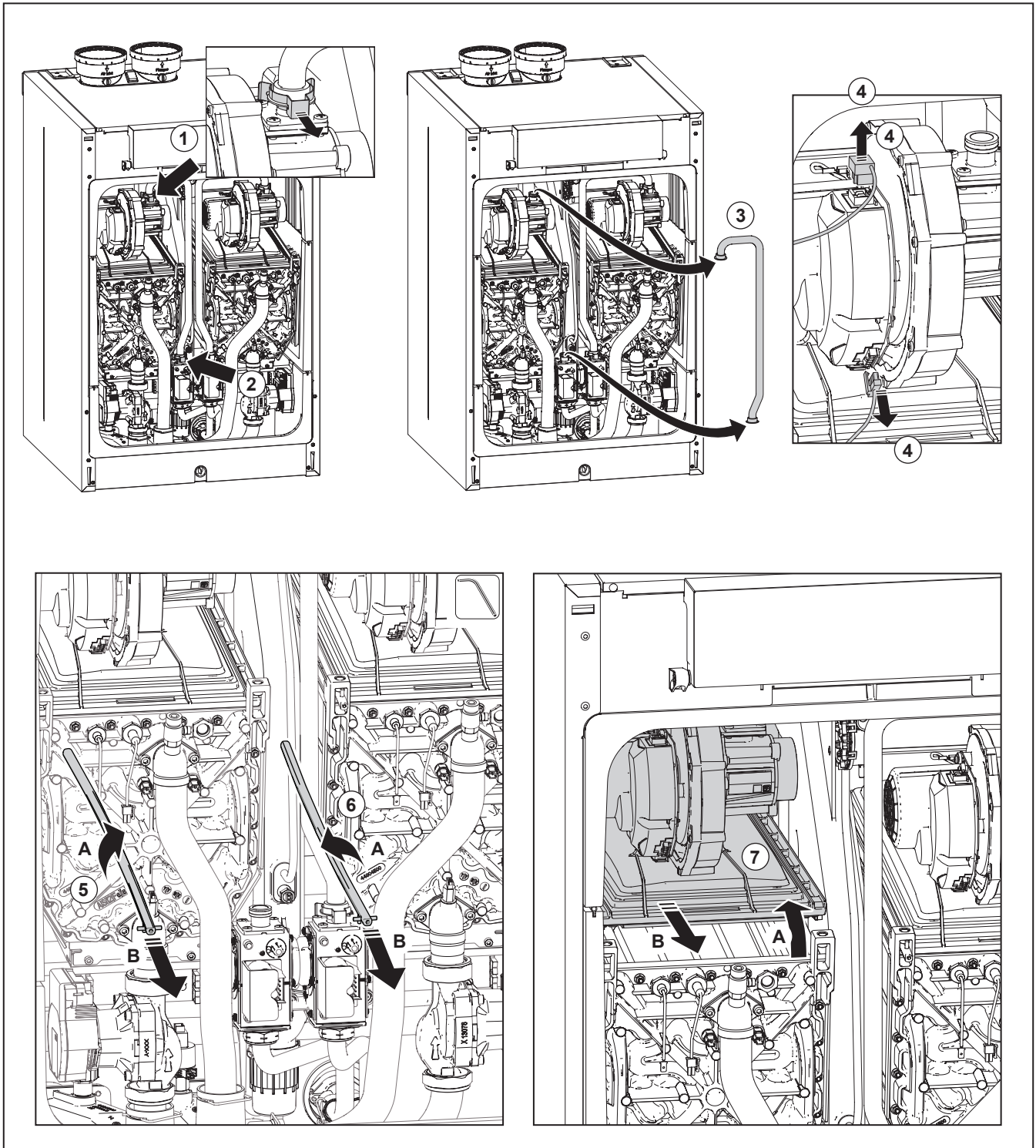

Maintenance

Maintenance details

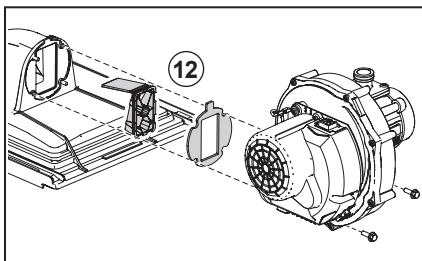
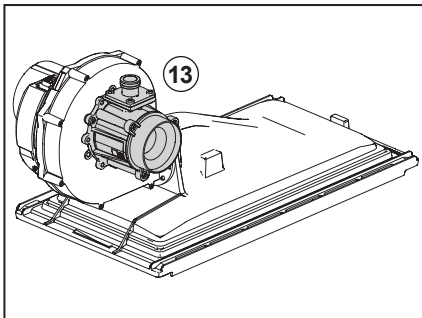
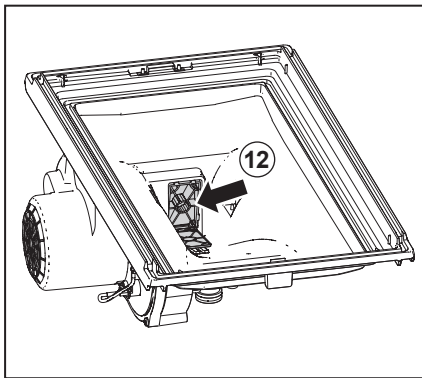
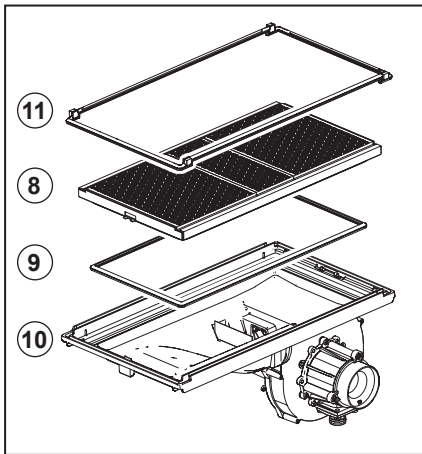

- Turn the unit up side down and remove the burner cassette (8) from the ventilator unit;
 - Check the burner cassette for wear and tear, pollution and any breakages. Clean the burner cassette with a soft brush and vacuum cleaner. In the case of breakages, always replace the complete burner cassette (8);
- The following operations must be performed carefully in relation to the vulnerability of the non return valve.

- After removing the burner cassette (8) the non return valve (12) becomes visible. Check that the non return valve entire circumference closes / seals completely. The valve (12) should be able to move freely from fully open to fully closed. Replace the non return valve if the valve does not seal properly. Follow the instructions supplied with the new part.
- Replace the gasket (9) between the burner (8) and upper casing (10) ;
- Replace the gasket (11) between the upper casing (10) and exchanger.
- Check the venturi (13) for pollution and clean them with a soft brush in combination with a vacuum cleaner, if necessary.

If the inside of the boiler casing is heavily polluted with dust, it is likely that the fan impeller is also polluted. To clean the fan, it has to be removed from the upper tray and the venturi. Clean the impeller with a soft brush and a vacuum cleaner. Replace the gasket and take care that the new gasket is installed properly when reassembling the fan parts.

Reassembly takes place in reverse order.

Heat exchanger

- Check the heat exchanger for pollution. Clean it, if necessary, with a soft brush and a vacuum cleaner. Avoid any pollution falling down.



NOTE: TOP-FLUSHING THE EXCHANGER WITH WATER IS NOT ALLOWED.

Reassembly takes place in reverse order.

During installation pay attention to the correct position of the clamp bars. These have to be in a vertical position.

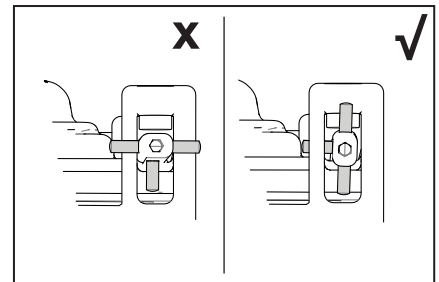
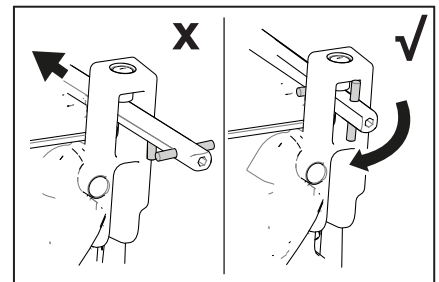

Maintenance

Maintenance details

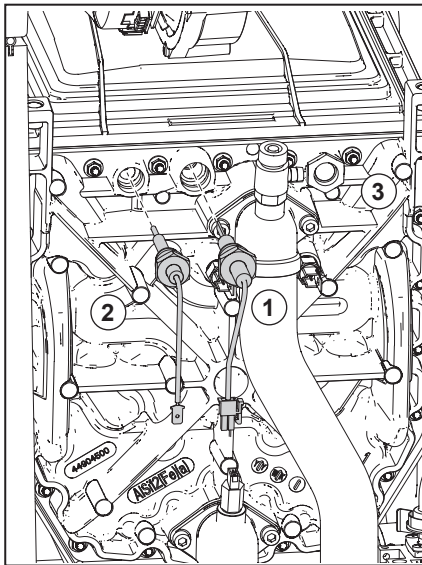

The ignition electrode

The ignition electrode (1) is a consumable part and must be checked

annually. The electrode must be renewed, if damages or any wear and tear is detected. The value of ignition electrode resistance can be detected through measurements.

The maximum electrode resistance at room temperature should not exceed 100 Ω.

It can be replaced unscrewing it from the heat exchanger. Remove and replace the o-ring. Make sure of the tightness of the connection. In case electrode damage is detected, verify the status and eventually replace the fuse along electrode cable.

In order to ensure continued good and safe operation of the boiler ignition electrode should be replaced every 2 years.

The detection electrode.

The detection electrode (2) is a

consumable part and must be checked annually. The electrode must be renewed, if damages or any wear and tear is detected, but certainly every 4 years. Furthermore, the value of the ionization current can be detected through measurements. Under full load operations, the minimum ionization current must amount to 4μ A.

It can be replaced unscrewing it from the heat exchanger. Remove and replace the o-ring. Make sure of the tightness of the connection.

Sight glass

If the sight glass (3) is damaged, it can be replaced unscrewing it from the heat exchanger. Remove and replace the gasket. Make sure the gasket is in correct position and the connection of new glass is tight.

Assembly is done in reverse order.

Checking the air pressure differential switch + side

- Switch off the boiler
- Disconnect the silicon hose on the + side (P1) of the air pressure differential switch (1).

- Take a large plastic syringe or bellows and connect a T piece with a hose connected (2).
- Connect the + side of the air-pressure differential switch to one end of the T piece with a hose (3).

- On the other end of the T piece, connect the + side of a pressure gauge (4).
- Turn on the boiler.
- Push the syringe or bellows in very slowly until the boiler goes into failure mode (5).
- Make a note of the pressure indicated by the pressure gauge at that point. A switch pressure of between 5.0 and 6.5 mbar is fine. A lower or higher switch pressure indicates a problem with the air pressure differential switch.
- After taking a measurement, detach the silicon hose from the T piece on the + side and reconnect the hose that was previously removed.

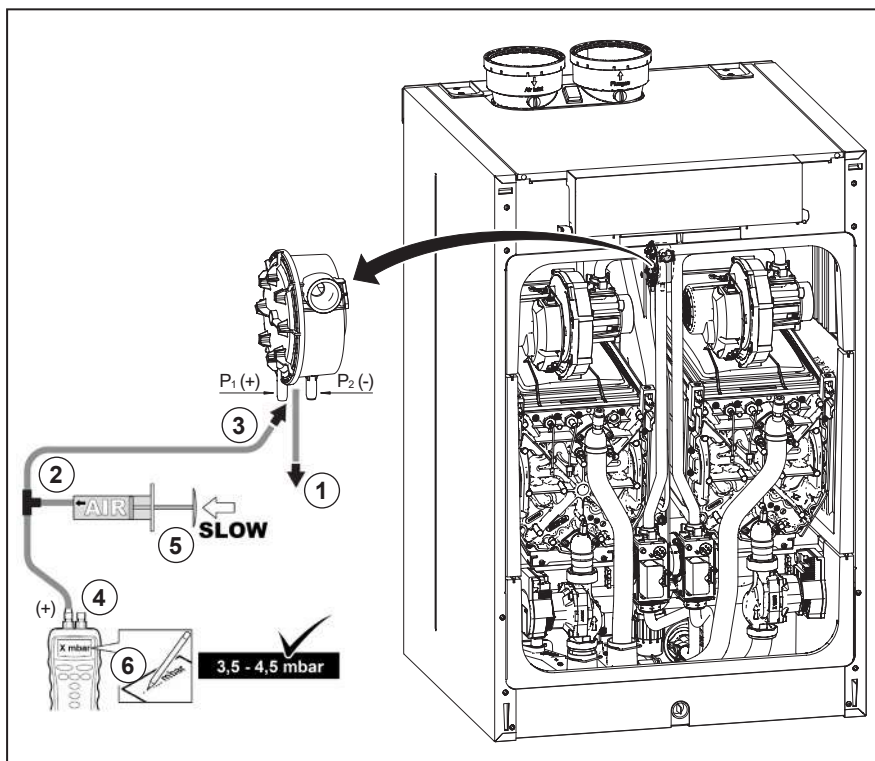

CAUTION:

Please note: The + side (P1) is the rear connector nipple of the air pressure differential switch (without red cap).

- Remove any soiling from all connection points for hoses and the air pressure differential switch.
- Check the condition and tightness of the hoses of the air pressure differential switch. Replace the hoses if necessary.

Maintenance

Maintenance details

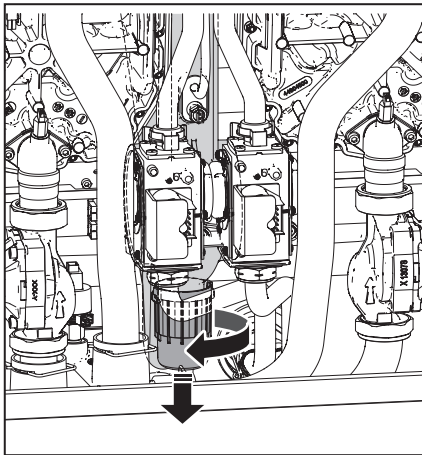

Dirt collector

Place a basin under the red dirt collector to collect the dirty and aggressive condensate water. Wear protective clothing like latex gloves and safety glasses.

- Dismantle the dirt collector by unscrewing it. Check the red cup for pollution.
- Clean it by rinsing it with water.
- Re-grease the O-rings with acidfree O-ring grease to facilitate easy assembly.
- If the red dirt collector shows any leakage, it has to be replaced.

In case of leakage you can remove the drainage cup to remove eventual water/condense from the boiler.

Take the device back into operation and conduct a flue gas analysis (refer to chapter Check O₂/CO₂).

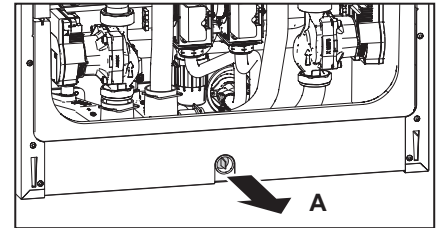

Maintenance warning

From factory a fixed number of running months is set for service interval. The number of running months cannot be changed. After expiring of the number of running months the message 1730 : Sched..Maintenance-Call Service (when read-out is on boiler status) is displayed on the screen.

During the messages 1730 : Sched..Maintenance-Call Service the boiler remains fully operational. If the maintenance activities, as described hereinbefore, have been carried out, the counter has to be reset. To reset the counter, the following procedure has to be followed (starting from a blue screen):

Go to installer menu
full menu
24.17 maintenance
24.17.2 reset maintenance counter.

The counter is reset to the same number of months as set from factory. The message 1730 : Sched..Maintenance-Call Service is no longer displayed.

Maintenance

Inspection overview

Pos. Nr.:	Inspection check list - Rendamax R1000	At least every 4.000 hrs.* once a year	Activity done	Remarks
	Switch off power supply to the boiler and close the gas valve!	√		
1	Air box/Boiler cover			
1.0.1	Remove boiler cover	√		
1.0.2	Check boiler cover/air box sealing on wear	√		
1.0.3	Necessary cleaning	√		
2	Gas pipes			
2.0.1	Check all gas pipes on leaks	√		
2.0.2	Check all gas fittings on leaks	√		
2.0.3	Check all gas pipes and parts on corrosion and damage	√		
2.0.4	Check static and dynamic gas pressure	√		
3	Pressure parts			
3.0.1	Check system pressure (Plausibility check)	√		
4	Checking parts on damage, corrosion, function and leaks:			
4.0.1	Gas valve / Venturi	√		
4.0.2	Automatic de-aerator	√		
4.0.3	Hydraulic connections	√		
4.0.4	Siphon dirt collector and condensate drain	√		
4.0.5	Ignition and detection electrode	√		
4.0.6	iConXL heat exchanger	√		
4.0.7	manual deareator	√		
5	Boiler/Burner in operation without air box/boiler cover:			
5.0.1	Check flame	√		
5.0.2	If flame is not stable - check adjustments and burner	√		
5.0.3	Commissioning O ₂ /CO ₂ and Ionisation current	√		
6	Additional checks:			
6.0.1	Check Air pressure switch proper functioning	√		
6.0.2	Check all parts under over-pressure	√		
6.0.3	Check combustion air intake	√		
6.0.4	Check gas flow (Plausibility check)	√		
6.0.5	Check O ₂ /CO ₂	√		
6.0.6	In case of multiple units - All activities should be carried out on all units!	√		
6.0.7	Reassemble boiler cover	√		
7	Boiler/Burner in operation with air box/boiler cover:			
7.0.1	Check function central heating	√		
7.0.2	Check function DHW	√		
7.0.3	Check desired temperature and actual flow temperature (Plausibi	√		
7.0.4	Write down running hours from HMI and reset counter	√		

* To verify with local service depending by installing condition

Maintenance

Maintenance overview

Pos. Nr.:	Maintenance check list - Rendamax R1000	At least every 16.000 hrs.* once a year	Activity done	Remarks
	Switch off power supply to the boiler and close the gas valve!	√		
1	Air box/Boiler cover			
1.0.1	Check cover on impurence and damage	√		
1.0.2	Necessary cleaning	√		
1.0.3	Check the sealing and replace if necessary	√		
2	Fan unit / Burner cassette			
2.0.1	Check and clean fan unit	√		
2.0.2	Check and clean top part heat exchanger	√		
2.0.3	Check non return valve and replace if necessary	√		
2.0.4	Check and clean burner cassette	√		
2.0.5	Check and clean venturi	√		
2.0.6	Check gas valve on corrosion and damage	√		
2.0.7	Replace all gaskets from gas system which are disassembled	√		
3	iConXL heat exchanger			
3.0.1	Check heat exchanger on corrosion and damage	√		
3.0.2	Check heat exchanger on impurence and clean	√		
3.0.3	Replace gasket between heat exchanger and burner cassette	√		
3.0.4	Replace gasket between heat exchanger and top part	√		
	Top-flushing the exchanger with water is not allowed!			
4	Checking parts on damage, corrosion, function and leaks and replace if necessary:			
4.0.1	Ignition and ionisation electrode	√		
4.0.2	Replace gasket ignition and ionisation electrode	√		
4.0.3	Automatic de-aerator	√		
4.0.4	Hydraulic connections	√		
5	Siphon dirt collector/Condensate drain			
5.0.1	Clean siphon dirt collector and condensate drain	√		
5.0.2	Check siphon dirt collector and condensate drain on leaks	√		
5.0.3	Replace gasket ignition and ionisation block	√		
5.0.4	Replace gaskets of siphon dirt collector	√		
5.0.5	Hydraulic connections	√		
6	Circulation pump			
6.0.1	Check circulation pump functions	√		
6.0.2	Check pump on external damage and check noise	√		
6.0.3	Check pump on leaks	√		
7	Additional activities:			
7.0.1	In case of multiple units - All activities should be carried out on all units!	√		
7.0.2	After complete maintenance follow inspection check list	√		
7.0.3	Open gas valve, switch on power supply	√		
7.0.4	Check function central heating	√		
7.0.5	Check function DHW	√		

* To verify with local service depending by installing condition

Errors

Error codes and fault finding

Cascade

Cascade master boiler

The cascade master display shows all errors that are known on the bus, so also from all slave boilers as from zone clip-in, solar manager, etc.

Cascade slave boiler

Shows only an error that is active on the slave boiler itself.

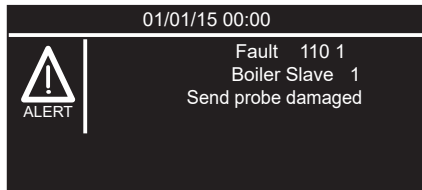

Error on cascade master from a slave boiler.

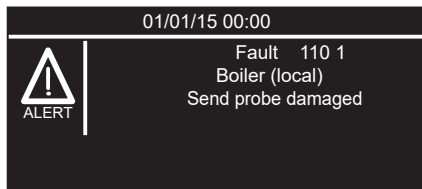

Error on the master itself.

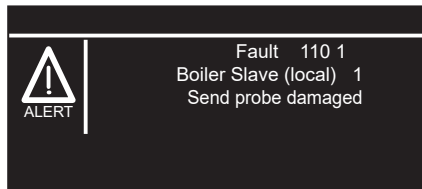

Error on a slave boiler itself.

Message on display (no indication of BHE0 and BHE1)	Fault Code engine 1	Fault Code engine 2 (if applicable)
Overheat	101 1	
Overheat		101 2
(Reserved)	--	
(Reserved)	--	
Flow Check 1	1P1 1	
Flow Check 1		1P1 2
Flow Check 3	1P2 1	
Flow Check 3		1P2 2
Flow Check 4	1P3 1	
Flow Check 4		1P3 2
Flow Check 2	104 1	
Flow Check 2		104 2
Flow Check 5	107 1	
Flow Check 5		107 2

Errors

Error codes and fault finding

Message on display (no indication of BHE0 and BHE1)	Fault Code engine 1	Fault Code engine 2 (if applicable)
(Reserved)	--	
(Reserved)	--	
(Reserved)	--	
(Reserved)	--	
Flow Sensor Open Short Circuit	110 1	
Flow Sensor Open Short Circuit		110 2
Return Sensor Open Short Circuit	112 1	
Return Sensor Open Short Circuit		112 2
Sensors Check	118 1	
Sensors Check		118 2
Flow Check 1 (or 3 or 4) Three Times	103 1	
Flow Check 1 (or 3 or 4) Three Times		103 2
Flow Check 3 (or 1 or 4) Three Times	105 1	
Flow Check 3 (or 1 or 4) Three Times		105 2
Flow Check 4 (or 1 or 3) Three Times	106 1	
Flow Check 4 (or 1 or 3) Three Times		106 2
(Reserved)	--	
(Reserved)	--	
Gas Relais check Failed	309 1	
Gas Relais check Failed		309 2
Pump Feedback Open Short Circuit	142 1	
Pump Feedback Open Short Circuit		142 2
PCB Fault 1	303 1	
PCB Fault 1		303 2
Too many Reset	304 1	
Too many Reset		304 2
Pump Feedback Abnormal Running	143 1	
Pump Feedback Abnormal Running		143 2
PCB Fault 2	306 1	
PCB Fault 2		306 2
Pump Feedback Abnormal Stopped	144 1	
Pump Feedback Abnormal Stopped		144 2
No Flame detection (3 attempts)	501 1	
No Flame detection (3 attempts)		501 2
False Flame	502 1	
False Flame		502 2
Flame lift (3 attempts)	504 1	
Flame lift (3 attempts)		504 2
No Flame 1	5P1 1	
No Flame 1		5P1 2

Errors

Error codes and fault finding

Message on display (no indication of BHE0 and BHE1)	Fault Code engine 1	Fault Code engine 2 (if applicable)
No Flame 2	5P2 1	
No Flame 2		5P2 2
Flame lift 1	5P3 1	
Flame lift 1		5P3 2
Pump Feedback Failure	145 1	
Pump Feedback Failure		145 2
Fan Error	612 1	
Fan Error		612 2
APS Open	603 1	
APS Open		603 2
Pump Feedback Low Flowrate	146 1	
Pump Feedback Low Flowrate		146 2
Flow2 Sensor Open Short Circuit	117 1	
Flow2 Sensor Open Short Circuit		117 2
Scheduled Maintenance	3P9 1	
Scheduled Maintenance		3P9 2
Bms Voltage Configuration Error	450	
Bms Current Configuration Error	451	
Bms External Configuration Error	452	
Buffer High Probe Error	730	
Buffer High Probe Overtemperature	731	
Buf Full Charge Error	732	
Boiler parametrization fault	162	
Boiler parametrization KO	163	
Boiler parametrization OK - waiting for NTCs	164	
Boiler parametrization missing	165	
Boiler parametrization allowed	166	
Boiler parametrization waiting for reset	167	
No Cascade Manager Detected	440	
Missing Boiler Detected	441	
Dynamic Pressure Check Failed	140 1	
Dynamic Pressure Check Failed		140 2
Dynamic Pressure Check Attempt Failed	1P9 1	
Dynamic Pressure Check Attempt Failed		1P9 2
Pump Feedback Low Warning Flowrate	1P0 1	
Pump Feedback Low Warning Flowrate		1P0 2
Flame Low Fan RPM High	506 1	
Flame Low Fan RPM High		506 2
Communication error (Internal HMI)	310	
Bus supply overload	420	

Errors

Reset a Fault code

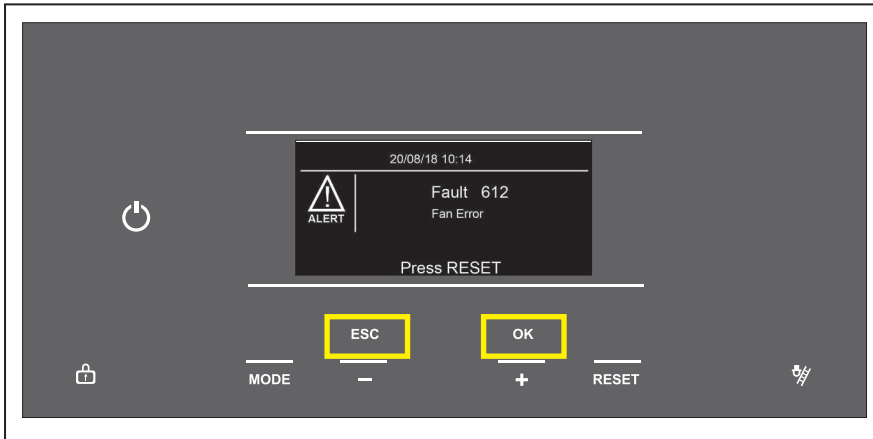

The settings are accessible through a code.

- 1 When an error occurs, the fault code and description appears on the screen.
- 2 To reset the fault code, press the **RESET** button.

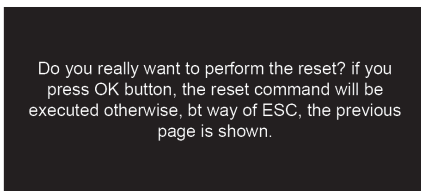

- 3 The message on the screen left appears. Press **OK** to reset the error, otherwise the previous screen is shown.

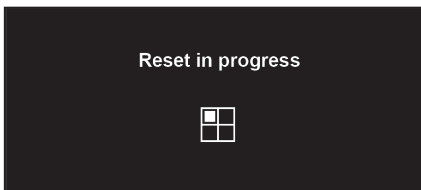

- 4 The **Reset in Progress** message appears.

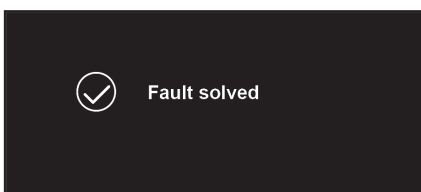

- 5 After a while the **Fault Solved** message appears.

After the code is reset, the Home screen appears.

When there are several errors active, it is possible to scroll trough them by pushing the ESC button. Last page is the main display. When there are no button activities for 30 sec., the last error will be displayed again. At the master boiler all errors of the cascade system will be displayed.

Errors

View Error code History

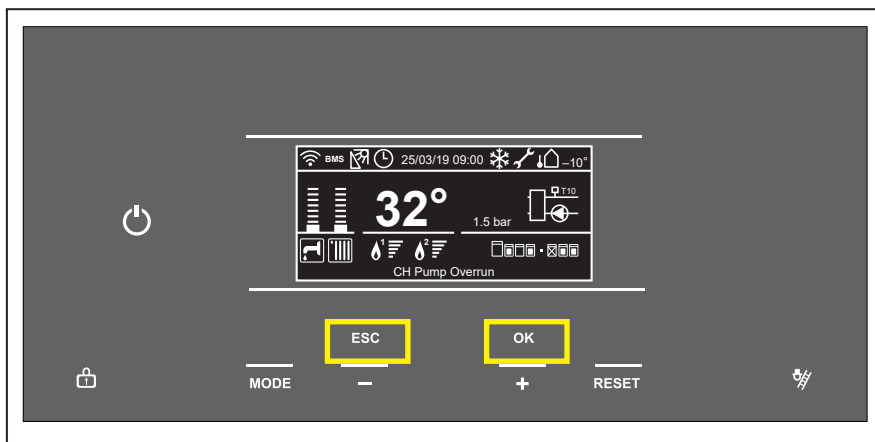

- 1 From the controller Home screen, press the **ESC** and **OK** buttons at the same time for 7 seconds.



- 2 Use **“+”** to go down and **“-”** to go up to highlight **007** as the Technical Code. Press **Save**.

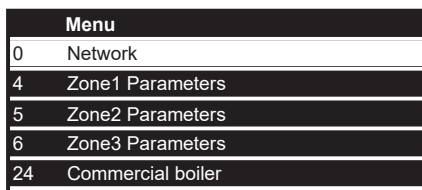

- 3 Use **“+”** to go down and **“-”** to go up to highlight **0 Network**. Press **OK**

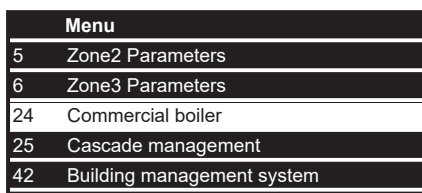

- 4 Use **“+”** to go down and **“-”** to go up to highlight **24 Commercial boiler**. Press **OK**.

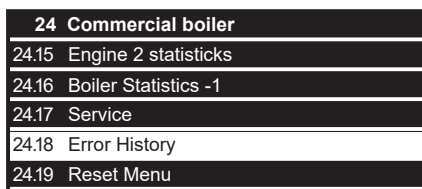

- 5 Use **“+”** to go down and **“-”** to go up to highlight **24.18 Error History**. Press **OK**.

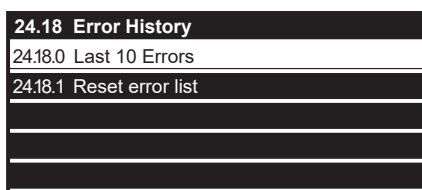

- 6 Option **24.18.0 Last 10 Errors** is highlighted. Press **OK**. A survey of the last 10 Errors appears.

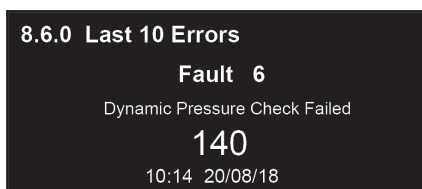

An example of an error message on the left.

Disposal and recycling

Device decommissioning

If the device has to be decommissioned please note the following points for dismantling and disposal:

- The decommissioning should only be performed by qualified specialist personnel, since certain activities are required on electrical components and fuel carrying lines.
- Switch off the main power supply to the device/ the device part and secure it against being switched back on.
- Check that the device / device part is de-energised.

Disposal of packaging material

The packaging materials used can be recycled. Please use the countryspecific recycling systems for professional and appropriate disposal or leave packaging materials with your specialist tradesman or dealer.

Device disposal

The device must be disposed of separately from general household waste and sent to a collection point for separate disposal of electrical and electronic devices (European Directive on Waste Electrical and Electronic Equipment WEEE 2012/19/EU), or must be taken back by a dealer when purchasing a new device of the same type. The user is responsible for ensuring that the device is properly disposed of at the end of its life. For more information on the disposal options available, contact your local authority or the dealer from whom the device was purchased.

Appendix

Sensor resistance

Sensor resistance

In the adjacent table contains a list of values for all boiler sensors, and for the optional sensors that are contained in the accessory kits.

These tables show average values, since all sensors are subject to fluctuations.

When measuring resistance values, the boiler should always be switched off. Carry out measurements near to the sensor, so as to avoid deviations from the values.

Heating flow sensor Heating return sensor DHW sensor Flue gas sensor	
NTC10k (25°C)	
Temperature [°C]	Resistance [Ohm]
-10	55.047
0	32.555
10	19.873
12	18.069
14	16.447
16	14.988
18	13.674
20	12.488
22	11.417
24	10.449
26	9.573
28	8.779
30	8.059
32	7.406
34	6.811
36	6.271
38	5.779
40	5.330
42	4.921
44	4.547
46	4.205
48	3.892
50	3.605
52	3.343
54	3.102
56	2.880
58	2.677
60	2.490
62	2.318
64	2.159
66	2.013
68	1.878
70	1.753
72	1.638
74	1.531
76	1.433
78	1.341
80	1.256
82	1.178
84	1.105
86	1.037
88	974
90	915

Outdoor temperature sensor	
NTC1k (25°C)	
Temperature [°C]	Resistance [Ohm]
-10	4.574
-9	4.358
-8	4.152
-7	3.958
-6	3.774
-5	3.600
-4	3.435
-3	3.279
-2	3.131
-1	2.990
0	2.857
1	2.730
2	2.610
3	2.496
4	2.387
5	2.284
6	2.186
7	2.093
8	2.004
9	1.920
10	1.840
11	1.763
12	1.690
13	1.621
14	1.555
15	1.492
16	1.433
17	1.375
18	1.320
19	1.268
20	1.218
21	1.170
22	1.125
23	1.081
24	1.040
25	1.000
26	962
27	926
28	892
29	858
30	827
35	687
40	575

Appendix

Standard schemes

Scheme	Boiler group	Distribution group
1	Single boiler or cascade	One direct zone
Name and Description	ECU I/O	Note
Boiler flow sensor	NTC1	
Boiler return sensor	NTC2	
Outdoor sensor	NTC4	
Boiler pump (230 V)	P1	
Boiler pump (PWM)	PWM_P1	
Common flow sensor (T10)	MTS1	
HC1 pump	MO1_HV	Pumps managed in parallel
System pump*	MO1_HV	
Heat request zone 1	PADIN1 or EBUS2	
Alarm or sanitary pump	VFR1	Optional
LPG/ Room supply Fan	VFR3	

*System pump: optional electrical connection. To use depending on application.

Appendix

Standard schemes

Scheme	Boiler group	Distribution group
2	Single boiler or cascade	Multiple direct zones
Name and Description	ECU I/O	Note
Outdoor sensor	NTC4	
Boiler pump (230 V)	P1	
Boiler pump (PWM)	PWM_P1	
Boiler flow sensor	NTC1	
Boiler return sensor	NTC2	
T10	MTS1	
HC1 pump	P_Z1	Controlled with CLIP 3 ZONE MIX. CLIP 3 ZONE MIX needed!
HC2 pump	P_Z2	
HC3 pump	P_Z3	
System pump*	MO1_HV	ON/OFF Pump.
Heat request zone 1	PADIN1 or EBUS2	
Heat request zone 2	PADIN2 or EBUS2	
Heat request zone 3	PADIN3 or EBUS2	
Alarm or sanitary pump	VFR1	Optional
LPG/ Room supply Fan	VFR3	

*System pump: optional electrical connection. To use depending on application.

Appendix

Standard schemes

Scheme	Boiler group	Distribution group
3	Single boiler or cascade	One or multiple mixing zones
Name and Description	ECU I/O	Note
Outdoor sensor	NTC4	
Boiler pump (230 V)	P1	
Boiler pump (PWM)	PWM_P1	
Boiler flow sensor	NTC1	
Boiler return sensor	NTC2	
T10	MTS1	
HC1 pump	P_Z1	Controlled with CLIP 3 ZONE MIX. CLIP 3 ZONE MIX needed!
HC1 mix valve	MV_Z1	
HC1 flow sensor	NTC_Z1	
HC2 pump	P_Z2	
HC2 mix valve	MV_Z2	
HC2 flow sensor	NTC_Z2	
HC3 pump	P_Z3	
HC3 mix valve	MV_Z3	
HC3 flow sensor	NTC_Z3	
System pump*	MO1_HV	
Heat request zone 1	PADIN1 or EBUS2	
Heat request zone 2	PADIN2 or EBUS2	
Heat request zone 3	PADIN3 or EBUS2	
Alarm or sanitary pump	VFR1	Optional
LPG/ Room supply Fan	VFR3	

*System pump: optional electrical connection. To use depending on application.

Combination of multiple zones (direct and/or mixed) can be done with CLIP 3 ZONE MIX. Final configuration can be created as a combination of scheme 2 and scheme 3.

Appendix

Standard schemes

Scheme	Boiler group	Distribution group
4	Single boiler or cascade	<ul style="list-style-type: none"> DHW tank downstream hydraulic separator From 1 to 3 mixing zone
Name and Description	ECU I/O	Note
Outdoor sensor	NTC4	
Boiler pump (230 V)	P1	
Boiler pump (PWM)	PWM_P1	
Boiler flow sensor	NTC1	
Boiler return sensor	NTC2	
DHW tank sensor	NTC3	
DHW pump	P2	
T10	MTS1	
HC1 pump	VFR1	See note *1
System pump*	MO1_HV	
Heat request zone 1	PADIN1 or EBUS2	
Alarm or sanitary pump	VFR1	Optional; see note *1
LPG/ Room supply Fan	VFR3	Optional

*System pump: optional electrical connection. To use depending on application.

Note:

- If all the VFR are needed for other functions (alarm, flue gas dumper, LPG, ...), HC1 pump must be connected to P_Z1 of Controlled with CLIP 3 ZONE MIX. CLIP 3 ZONE MIX is needed!

Declaration of Conformity

We, ELCO BV, Hamstraat 76, 6465 AG Kerkrade
declare under our responsibility that the product

R1060-R1070-R1100-R1120-R1140-R1170-R1200

is in conformity with the following standards:

EU Gas Appliances Regulation	2016/426/EU	EN 15502-2: 2012 EN 15502-1: 2012 EN 298: 2012	EN 60335-1: 2012 EN 60335-2-102: 2016
Boiler Efficiency Directive	92/42/EEC	EN 15502-1: 2012	
Low Voltage Directive	2014/35/EU	EN 60335-1: 2012 EN 60335-2-102: 2016	
EMC Directive	2014/30/EU	EN 61000-3-2: 2019 EN 61000-3-3: 2013 EN 60335-2-102: 2016	EN 55014-1: 2017 EN 55014-2: 2015
Ecodesign Directive	2009/125/EU 2017/1369/EU	EN 13203-2: 2018 EN 15036-1: 2006 EN 15502-1: 2012 regulation (EU) 813/2013 regulation (EU) 811/2013	
Restriction of Hazardous Substances	2011/65/EU		

This product is designated with CE number:

CE – 0063CT3449

Kerkrade, 12.06.2020

ELCO BV



i.V. Stefan Salewsky

Service: